

JUKI®

No. 0010-02
1977・1

model **DDL-227** サブクラス
& SUBCLASSES

高速一本針本縫ミシン

Single Needle Lockstitch
Industrial Sewing Machine

PARTS BOOK

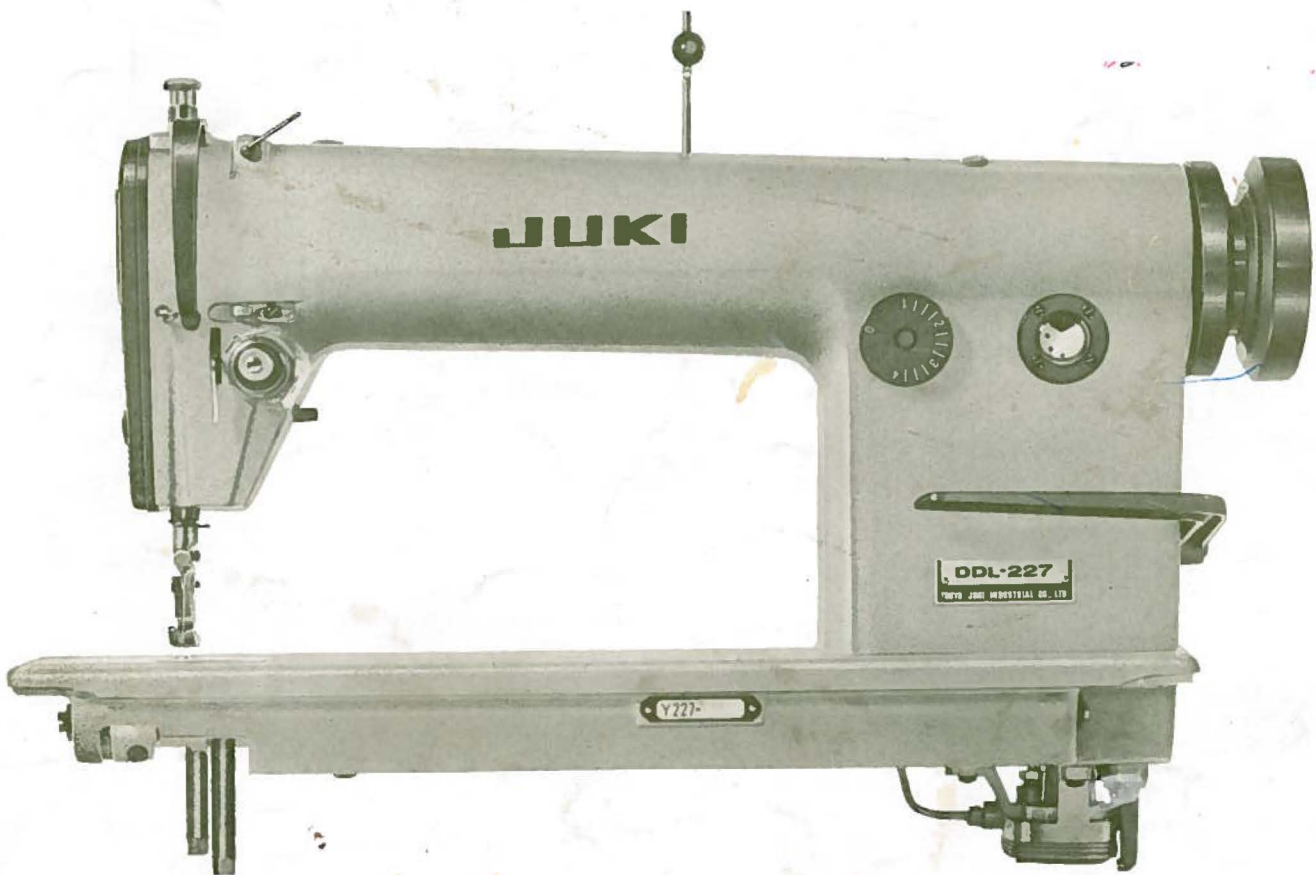

TOKYO JUKI INDUSTRIAL CO., LTD.

From the library of: Superior Sewing Machine & Supply LLC

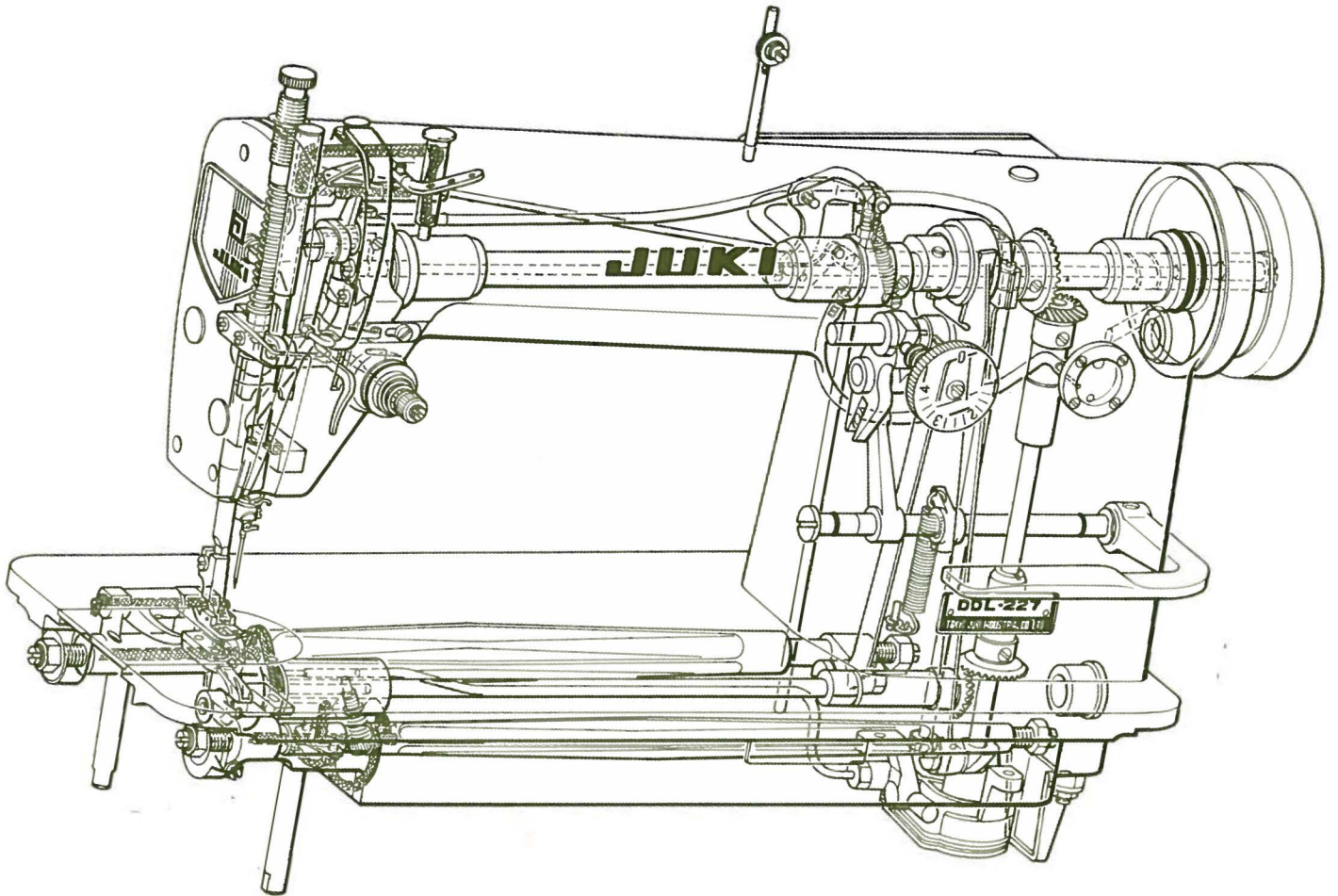

HOW TO MAKE USE OF THIS PARTS BOOK

1. As a basic principle, this parts book is divided into various sections according to the functions of respective parts.
2. The part numbers of parts shown in the figure indicate the corresponding numbers(Ref.No.) shown by the Index.

3. Explanation of codes

- 1) ① ☆ mark means this part is changed from the previous parts book.
 ② 01, 02 refer to "Note" explanation at bottom of page.
- 2) Codes on the "E. C. (Engineering change)" column
 ① A.10/74 Added from October, 1974
 ② D.1/75 Obsoleted from January, 1975
 ③ When D.(obsoleted) and A.(added) are indicated together
 D.12/74
 A.12/74
 ④ When previous parts (Obsoleted part) and new parts (Added parts) are not interchangeable with each other:
 In this case, even obsoleted parts(D.) can be ordered with the obsoleted part number, so select the parts with changed dates and place your orders.

(Example)

Ref. No.	Note	Part No.	Description	E. C.	品 名	Amt. Req.
	注記	品 番		変更年月		数量
1	☆	B1401-100-000	Needle bar	D.12/74	ハリボー	—
1-1	☆	B1401-100-000-A	Needle bar	A.12/74	ハリボー	1

- ⑤ In case when previous parts and new part are interchangeable with each other:
 In this case the new part number is replaced on the "品名(Japanese)" column of the previous parts, so please order by the new part number.

(Example)

Ref. No.	Note	Part No.	Description	E. C.	品 名	Amt. Req.
	注記	品 番		変更年月		数量
1	☆	B1105-200-000	Frame cover	D.12/74	B1105-300-000	—
	☆	B1105-300-000	Frame cover	A.12/74	フレームカバー	1

- ④ C.3/75 This indicates error was discovered in March, 1975 and so it was corrected to a new part number.
 Please note that in this case, the corrected part number is shown in the part number column and the wrong part number is shown in the "品名(Japanese)" column, so please order by the correct part number.

(Example)

Ref. No.	Note	Part No.	Description	E. C.	品 名	Amt. Req.
	注記	品 番		変更年月		数量
1	☆	B1105-500-000	Frame cover	C.3/75	B1105-600-000	1
		↓ Correct No.			↑ Wrong No.	

- ⑤ M.5/75 The amount required is changed from March, 1975
 The new amount required is shown in the "Amt. Req." column.

3) Codes on the "Amt. Req." column

- ① 2 Indicates amount required is 2.
- ② 2.0 Indicates length in meters. (unit is meter)
- ③ — Indicates parts obsoleted from the parts book.
- ④ (1) Indicates sub parts which construct the assembly part.
 Assembly part is shown as "asm." and クミ in Japanese, in the "Description" column.

(Example)

Ref. No.	Note	Part No.	Description	E. C.	品 名	Amt. Req.
	注記	品 番		変更年月		数量
10		B1105-900-0A0	Frame cover asm.		フレームカバー クミ	1
11		B1105-900-000	Frame cover		フレームカバー	(1)
12		SS-8110310-SP	Screw 11/64-40 L=2.8		トメネジ 11/64-40 L=2.8	(2)

パーツブックの見方

- このパーツブックは、原則として、機構別に分類された各項目からなっております。
- 図に示された部品の品番は、図にふられている No.(Ref. No.) に対応するインデックスによって、その品番がわかります。
- 記号の説明

1) "注記" 欄の記号

- ☆印………前回のパーツブックと比較して今回変更された部品を意味します。
- ◇01、◆02………ページ下の"注記"の説明を参照して下さい。

2) "変更年月" 欄の記号

- A. 10/74………1974年10月より追加された。
- D. 1/75………1975年1月より削除された。
- D. (削除)、A. (追加) が連記してある場合。

D. 12/74
A. 12/74

(a) 部品の互換性がない変更の場合

この場合は削除 (D) された品番でも御注文できますから、変更年月により、いずれかの部品を選択して御注文下さい。

Ref. No.	Note	Part No.	Description	E.C.	品名	Amt. Req. 数量
1	☆	B1401-100-000	Needle bar	D.12/74	ハリボー	—
1-1	☆	B1401-100-000-A	Needle bar	A.12/74	ハリボー	1

(b) 部品の互換性がある場合の変更

この場合は、旧部品の和文品名欄にそれにかわる新しい品番が記入してありますので、新しい品番で御注文下さい。

Ref. No.	Note	Part No.	Description	E.C.	品名	Amt. Req. 数量
1	☆	B1105-200-000	Frame cover	D.12/74	B1105-300-000	—
	☆	B1105-300-000	Frame cover	A.12/74	フレームカバー	1

- C 3/75………1975年3月に品番のミスが判明した為、正しい品番に訂正された。
この場合は品番欄に正しい品番を、和文品名欄に間違いの品番が記入してありますので、正しい品番で御注文下さい。

Ref. No.	Note	Part No.	Description	E.C.	品名	Amt. Req. 数量
1	☆	B1105-500-000	Frame cover	C.3/75	B1105-600-000	1
		↑ 正しい品番			↑ 間違っていた品番	

- M. 5/75………1975年5月より数量が変更になった。
この場合数量欄には新しい数量が表示してあります。

3) "数量" 欄の記号

- 2………数量、2個を表わします。
- 2.0………長さ、2メートルを表わします。(単位はメートルです)
- ………このパーツブックから削除された部品です。
- (1)………組部品を構成している子部品を表わします。
組部品は品名欄に英文で "asm." 和文で "クミ" と表示してあります。

Ref. No.	Note	Part No.	Description	E.C.	品名	Amt. Req. 数量
10		B1105-900-0A0	Frame cover asm.		フレームカバー クミ	1
11		B1105-900-000	Frame cover		フレームカバー	(1)
12		SS-8110310-SP	Screw 11/64-40 L=2.8		トメネジ 11/64-40 L=2.8	(2)

CONTENTS

目次

1. FRAME & MISCELLANEOUS COVER COMPONENTS	
頭部外装関係	2
2. MAIN SHAFT, NEEDLE BAR COMPONENTS	
上軸, 針棒関係	4
3. HOOK DRIVING SHAFT, PRESSER BAR, KNEE LIFTER COMPONENTS	
下軸, 押エ棒, 膝上ゲ関係	6
4. FEED COMPONENTS	
送り関係	8
5. OIL LUBRICATION COMPONENTS	
給油関係	9
6. OIL RESERVOIR & KNEE LIFTER COMPONENTS	
油留, 膝上ゲ関係	10
EXCLUSIVE PARTS LIST OF DDL-227 SUBCLASS SEWING MACHINES	
DDL-227 サブクラス専用部品一覧表	11
7. SUBCLASS MACHINES	
サブクラスマシン	12
1. DDL-227-A	12
2. DDL-227-H	12
3. DDL-227-M	13
4. DDL-227-W	13
5. DDL-227-L	14
8. SPECIAL ORDER PARTS	
特別注文部品	14
9. NUMERICAL INDEX OF PARTS	
索引	15

1. FRAME & MISCELLANEOUS COVER COMPONENTS

頭部外装関係

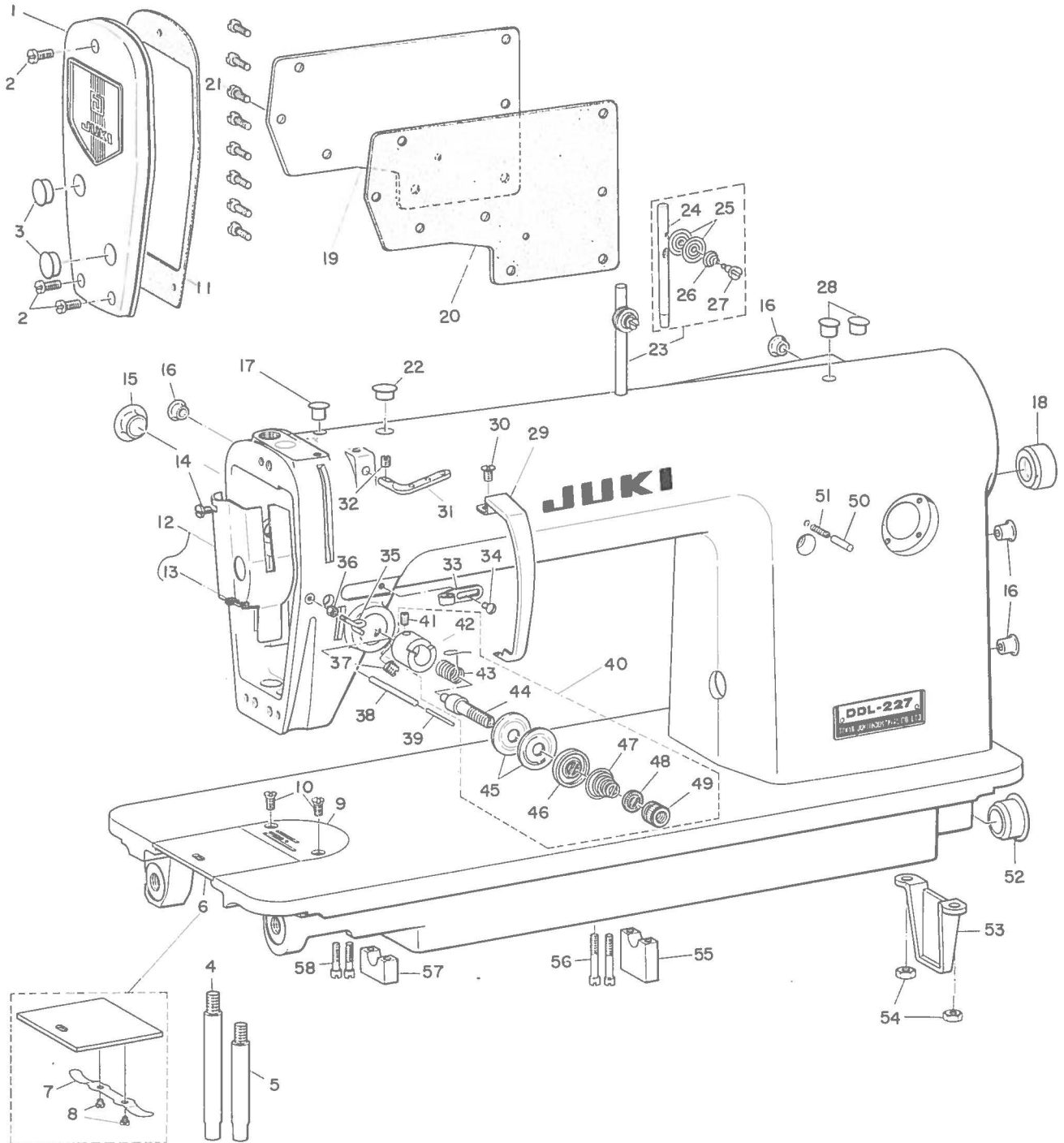

1. FRAME & MISCELLANEOUS COVER COMPONENTS

頭部・外装関係

Ref. No.	Note	Part No.	Description	E.C.	Amt. Req.
	注記	品番		変更年月	数量
1		B1121-552-0A0	Face plate asm.		1
2		SS-7111120-SP	. . . Screw		3
3		B1179-552-000 rubber plug		2
4		B1104-122-000	Bed screw stud (A)		1
5		B1105-122-000	Bed screw stud (B)		1
6		B1110-012-0A0	Bed slide asm.		1
7		B1111-012-000	Bed slide spring		(1)
8		SS-6060210-SP	. . . Screw		(2)
9	◆01	B1109-012-A00	Throat plate (A)		1
10		SS-2110920-TP	. . . Screw		2
11		B1122-552-000	Face plate gasket		1
12		B1188-552-0A0	Arm oil shield asm.		1
13		CQ-2020000-00	. . . Screw		(0.1)
14	◆01	SS-6080410-SP	. . . Oil wick		1
15		B1164-012-000	Counterweight screw hole plug		1
16		B1117-552-000	Rubber plug		4
17		B1117-552-000	Rubber plug		1
18		B1189-415-000	Rubber plug for adjuster hole		1
19		B1118-522-000	Side plate		1
20		B1119-522-000	. . . Gasket		1
21		SS-7110910-SP	. . . Screw		8
22		B1187-552-000	Rubber plug		1
23	◆01	B1113-155-0A0	Needle thread guide pin asm.		1
24		B1113-155-000	Needle thread guide pin		(1)
25		B3148-123-000	. . . Tension disc		(2)
26		B3149-123-A00	. . . Spring		(1)
27		SD-0380552-SL Stud		(1)
28		B1186-552-000	Rubber plug		2
29		B1123-552-000-A	Thread take-up lever cover		1
30		SS-7110510-SP	. . . Screw		1
31		B1128-522-000	Three-hole thread eyelet		1
32		SS-8110510-SP	. . . Screw		1
33	◆01	B1126-552-000	Frame thread guide (A)		1
34		SS-5090610-SP	. . . Screw		1
35		B3114-761-000	Frame thread guide (B)		1
36		NS-6060350-SP	. . . Nut		1
37		SS-8150710-SP	Thread tension post clamp screw		1
38		B3127-127-000	Tension release auxiliary pin		1
39		B3118-552-C00	Tension release pin		1
40		B3111-552-0A0	Thread tension post asm.		1
41		SS-8090670-SP	Screw		(1)
42	◆01	B3111-552-B00	Thread tension post socket		(1)
43	◆01	B3128-012-000	Take-up spring		(1)
44		B3115-552-000	Thread tension post		(1)
45		B3126-012-000	Thread tension disc		(2)
46		B3132-552-000	. . . Presser		(1)
47	◆01	B3129-012-A00	Thread tension spring		(1)
48		B3120-125-000	Thread disc rotation stopper		(1)
49		B3116-125-000	Thread tension nut		(1)
50		B1147-555-000	Feed regulator pin		1
51		B1148-555-000	. . . Spring		1
52		B1166-552-000-A	Hookshaft rubber plug		1
53		B1106-122-000	Bed support		1
54		NS-6150310-SP	. . . Nut		2
55		B1108-122-000	Feed driving shaft support block		1
56		SS-6092420-SP	. . . Screw		2
57		B1107-122-000	Feed rock shaft support block		1
58		SS-6091510-SP	. . . Screw		2

Note (注記) ◆01 Standard parts 標準部品

2. MAIN SHAFT, NEEDLE BAR COMPONENTS

上軸, 針棒關係

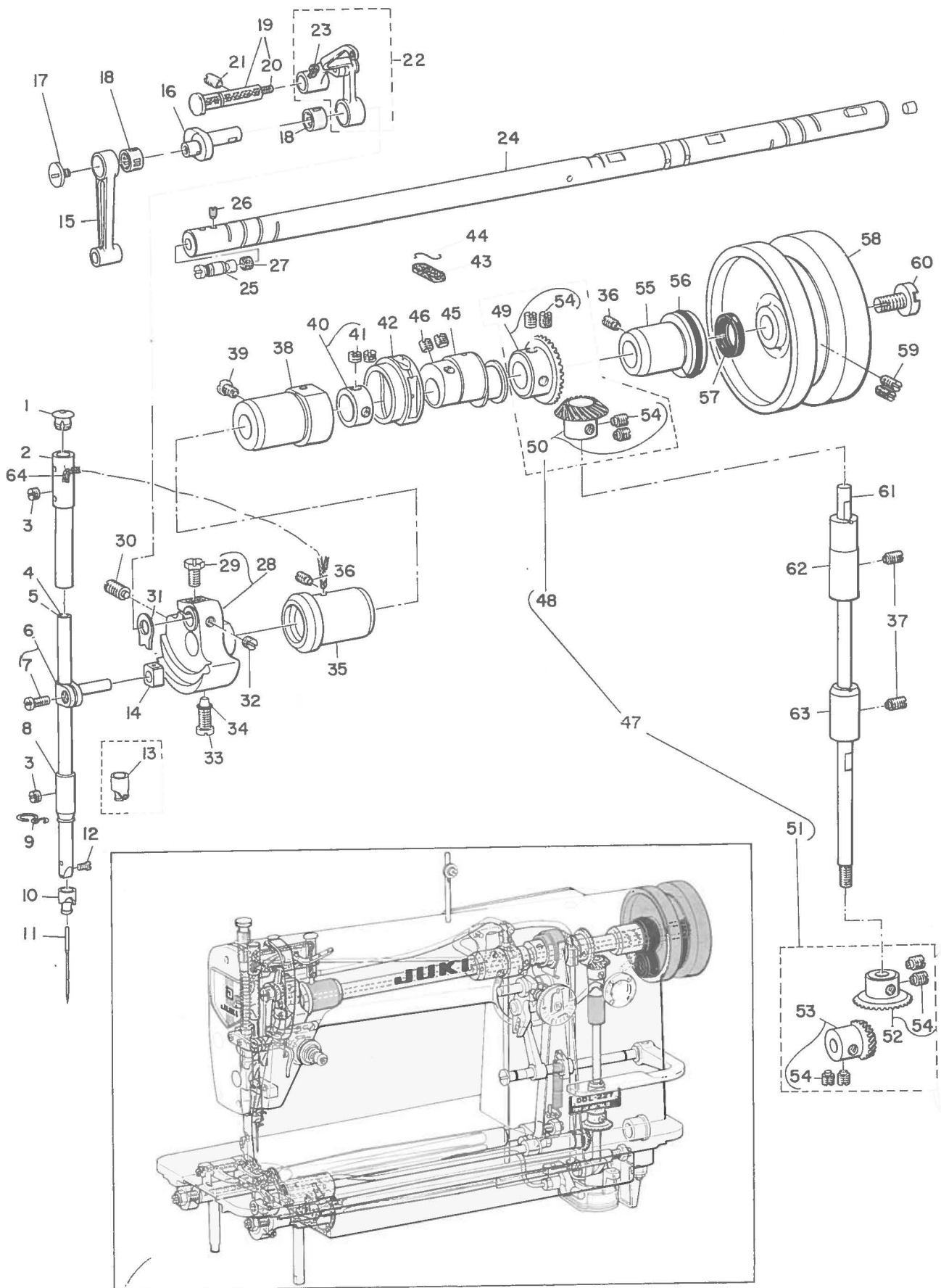

2. MAIN SHAFT, NEEDLE BAR COMPONENTS

上軸・針棒関係

Ref. No.	Note	Part No.	Description	E.C.	Amt. Req.
	注記	品番		変更年月	数量
1		B1405-012-000	Rubber plug	針棒上メタル蓋	1
2		B1402-552-000-A	Needle bar bushing, upper	針棒上メタル	1
3		SS-8150310-SP	. . . Screw	針棒上メタル止ネジ	2
4	◆01	B1401-552-A00	Needle bar (A)	針棒 (A)	1
5	◆01	B1401-552-B00	Needle bar (B)	針棒 (B)	1
6		B1411-552-0A0	Needle bar connection asm.	針棒抱キ (組)	1
7		SS-6090670-TP	. . . Clamp screw	針棒抱キ締ネジ	(1)
8	◆01	B1403-155-000	Needle bar bushing, lower	針棒下メタル	1
9	◆01	B1419-155-000	Needle bar thread guide	針棒糸案内	1
10	◆01	B1418-541-000	Needle bar thread guide	針棒糸掛ケ	1
11	◆01	MDB-100B1400	Needle (DBx1)	針 (DB×1、≠14)	1
12		SS-7080510-SP	. . . Screw	針止ネジ	1
13	◆01	B1418-227-T00	Needle bar thread guide (T)	針棒糸掛ケ (T)	1
14		B1414-232-000	Needle bar connection guide block	針棒抱キ案内コロ	1
15		B1408-552-000	Needle bar crank connecting rod	針棒クランクロッド	1
16	◆01	B1209-552-000	Needle bar crank	針棒クランク	1
17		B1903-552-000	Thread take-up crank left screw	天ビンクランク左ネジ	1
18		B1905-541-B00	Needle shaft bushing	天ビンニードル軸受	2
19		B1904-552-0A0	Thread take-up crank shaft stud asm.	天ビンクランク軸 (組)	1
20		CQ-2020000-00	. . . Oil wick	天ビンクランク軸油心	(0.2)
21		SS-8151150-SP	. . . Screw	天ビンクランク軸止ネジ	1
22		B1901-552-0C0	Thread take-up lever asm.	リンク天ビン (組)	1
23		CQ-2000000-00	. . . Oil wick	リンク天ビン油心	(0.1)
24		B1201-227-000	Main shaft	上軸	1
25		B1213-552-0A0	Crank oil adjusting pin	クランク油量調節ピン	1
26		B1224-552-000	. . . Screw	クランク油量調節ピン止ネジ	1
27		B1226-552-000	. . . Regulating felt	クランク油量制限フェルト	1
28	◆01	B1206-552-0A0	Counterweight asm.	釣合錘 (組)	1
29		SS-9661120-CP	. . . Clamp screw	針棒クランク締付ネジ	(1)
30		SS-8681950-SP	Screw (B)	釣合錘止ネジ (B)	1
31		B1212-552-A00	. . . Wearing plate	釣合錘保護板	1
32		SS-8660610-TP	. . . Screw	針棒クランク止ネジ	1
33		SS-7681650-TP	Screw (A)	釣合錘止ネジ (A)	1
34		RO-0442401-00	. . . Rubber ring	釣合錘止ネジOリング	1
35		B1202-552-000-A	Main shaft bushing, front	上軸前メタル	1
36		SS-8151150-SP	. . . Screw	上軸メタル止ネジ	2
37		SS-8151150-SP	Uplight shaft bushing screw	立軸メタル止ネジ	2
38		B1203-227-000	Main shaft bushing, intermediate	上軸中メタル	1
39		SS-7151120-SP	. . . Screw	上軸中メタル止ネジ	1
40		CS-147121A-SH	Main shaft thrust collar	上軸スラスト受ケ	1
41		SS-8660610-TP	. . . Screw	上軸スラスト受ケ止ネジ	(2)
42		B1211-226-000	Forked rod sleeve	二又サヤ	1
43		B1212-012-000	. . . Felt	二又サヤフェルト	1
44		B1213-012-000	. . . Felt presser	二又サヤフェルト押エ	1
45	◆01	B1210-226-000	Feed drive eccentric cam	送り偏心カム	1
46		SS-8150710-TP	. . . Screw	送り偏心カム止ネジ	2
47		B1306-155-0C0	Gear & Pinion asm.	上下傘歯車 (組)	1
48		B1306-155-0B0	Gear & Pinion asm., upper	上傘歯車 (組)	(1)
49		B1305-012-0A0	Gear (LARGE)	上傘歯車 (大)	(1)
50		B1306-155-0A0	Pinion (SMALL)	上傘歯車 (小)	(1)
51		B1307-155-0B0	Gear & pinion asm., lower	下傘歯車 (組)	(1)
52		B1307-155-0A0	Gear (LARGE)	下傘歯車 (大)	(1)
53		B1308-155-0A0	Pinion (SMALL)	下傘歯車 (小)	(1)
54		SS-8660810-TP	. . . Screw	歯車止ネジ	(8)
55		B1204-552-B00	Main shaft bushing (B), rear	上軸後メタル (B)	1
56		RO-2943101-00	. . . Rubber ring	上軸後メタルOリング	1
57		B1208-552-000-A	. . . Oil seal ring	上軸後メタルオイルシール	1
58		B1217-555-000	Hand wheel	ハズミ車	1
59		SS-8151550-SP	. . . Screw	ハズミ車止ネジ	2
60		B1233-012-000	. . . End screw	ハズミ車押し上げネジ	1
61		B1301-552-000	Upright shaft	立軸	1
62		B1302-552-000-A	. . . Bushing, upper	立軸上メタル	1
63		B1303-552-000-A	. . . Bushing, lower	立軸下メタル	1
64		CQ-2020000-00	Oil wick	針棒給油油心	0.3

Note (注記) ◆01 Special order parts 特別注文部品
 ◆01 Standard parts 標準部品

3. HOOK DRIVING SHAFT, PRESSER BAR, KNEE LIFTER COMPONENTS

下軸, 押工棒, 膝上ケ関係

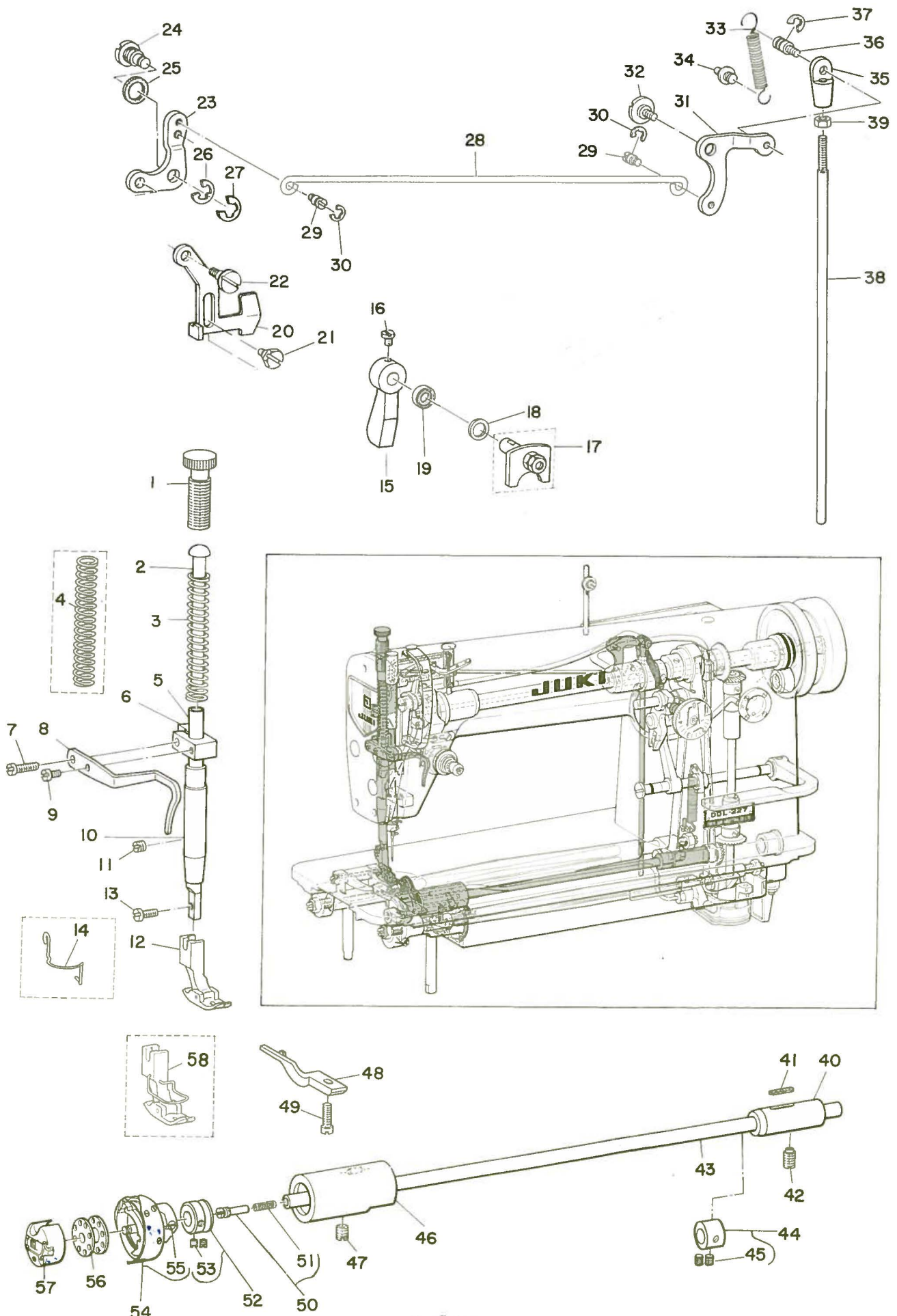

3. HOOK DRIVING SHAFT, PRESSER BAR, KNEE LIFTER COMPONENTS 下軸・押工棒・膝上ゲ関係

Ref. No.	Note	Part No.	Description	E.C.	品名	Amt. Req.
	注記	品番		変更年月		数量
1		B1509-227-000	Presser spring regulator		押工調節ネジ	1
2		B1510-227-000	Presser guide bar		押工案内棒	1
3	◆01	B1505-227-000-A	Presser spring		押工調節バネ	1
4	◎01	B1505-227-T00-A	Presser spring (T)		押工調節バネ (T)	1
5		B1501-127-000	Presser bar		押工棒	1
6		B1507-552-000	Presser bar guide bracket		押工棒抱キ	1
7		SS-7111410-SP	. . . Clamp screw		押工棒抱キ締ネジ	1
8		B1521-552-000	Presser bar clamp thread guide		押工棒抱キ糸案内	1
9		SS-6090650-SP	. . . Screw		押工棒抱キ糸案内止ネジ	1
10		B1502-541-000	Presser bar lower bushing		押工棒下メタル	1
11		SS-8150310-SP	. . . Screw		押工棒下メタル止ネジ	1
12	◆01	B1524-012-0A0	Hinged presser foot asm.		自由押工 (組)	1
13		SS-7091110-SP	. . . Screw		自由押工止ネジ	1
14	◎01	B1421-522-000	Needle bar guard		針棒安全カバー	1
15		B1520-552-000	Hand lifter lever		押工上ゲレバー	1
16		SS-7120910-SP	. . . Screw		押工上ゲレバー止ネジ	1
17	◆01	B1518-552-0A0	Hand lifter cam asm.		押工上ゲカム (組)	1
18		WP-0740516-SP	Washer		押工上ゲ軸座金	1
19		B1522-552-000	Oil seal		押工上ゲ軸オイルシール	1
20		B1515-552-000	Lifting lever		引キ上ゲ板	1
21		SD-0630275-SP	. . . Hinge screw (A)		引キ上ゲ板段ネジ (A)	1
22		SD-0630301-SP	. . . Hinge screw (B)		引キ上ゲ板段ネジ (B)	1
23		B1516-552-000 Lifting lever link		引キ上ゲ板リンク	1
24		B1517-552-000	. . . Link shaft		引キ上ゲ板リンク軸	1
25		B3431-581-000 Gasket		引キ上ゲ板リンク軸パッキン	1
26		RE-0600000-KO Snap ring		引キ上ゲ板リンク軸止メ環	1
27		B1523-226-000 Snap ring (B)		引キ上ゲ板リンク軸止メ環 (B)	1
28		B3412-552-000	Lifting lever connecting rod		ヒザ上ゲ横棒	1
29		B3416-552-000	. . . Hinge screw		ヒザ上ゲ横棒段ネジ	2
30		RE-0500000-KO	. . . Snap ring		ヒザ上ゲ横棒止メ環	2
31		B3414-552-000	Lifting lever link arm		ヒザ上ゲリンク腕	1
32		SD-0720331-SP	. . . Hinge screw		ヒザ上ゲリンク腕段ネジ	1
33		B3417-552-000	. . . Spring		ヒザ上ゲリンク腕バネ	1
34		B3413-227-000 Suspension screw		ヒザ上ゲリンク腕バネ掛ケ軸	1
35		B3416-012-000	Swivel		ツリ棒ダルマ	1
36		B3418-552-000	. . . Screw		ツリ棒ダルマ止ネジ	1
37		RE-0500000-KO Snap ring		ツリ棒ダルマ止ネジ止メ環	1
38		B3415-552-000 Connecting rod, vertical		ヒザ上ゲ連結棒	1
39		NS-6620310-SP	. . . Nut		ヒザ上ゲ連結棒ナット	1
40		B1804-226-000	Hook driving shaft bushing, rear		下軸後メタル	1
41		B1806-038-000	. . . Oil felt		下軸後メタルフェルト	1
42		SS-8151550-SP	. . . Screw		下軸後メタル止ネジ	1
43		B1801-412-000	Hook driving shaft		下軸	1
44		CS-0791010-SH	Hook driving shaft thrust collar (B)		下軸スラスト受ケ (B)(組)	1
45		SS-8110520-TP	. . . Screw		下軸スラスト受ケ (B) 止ネジ	(2)
46		B1802-412-0A0	. . . Bushing asm, front		下軸前メタル	1
47		SS-8151150-SP	. . . Screw		下軸前メタル止ネジ	1
48	◆01	B1835-012-000	Bobbin case holder positioning finger		中釜押工	1
49		SS-6111010-SP	. . . Screw		中釜押工止ネジ	1
50	◆01	B1808-552-0A0	Lower shaft front screw		下軸前止ネジ	1
51		B1809-552-0A0	. . . Oil wick	D.7/75	B1810-552-000	—
		B1810-552-000	. . . Oil wick	A.7/75	下軸前止ネジ油心	1
52		CS-079106A-SH	Hook driving shaft thrust collar		下軸スラスト受ケ (組)	1
53		SS-8110410-TP	. . . Screw		下軸スラスト受ケ止ネジ	(2)
54	◆01	B1830-127-0A0	Lubricating hook asm.		給油釜 (組)	1
55		SS-6110560-TP	. . . Screw		外釜止ネジ	(2)
56	◆01	B1837-012-0A0	Bobbin case asm.		ポビンケース (組)	1
57	◆01	B9117-012-000	Bobbin		ポビン	1
58	☆01	B1524-012-0B0	Hinged presser foot asm.	A.3/76	自由押工 (組)	1

Note (注記) ◆01 Special order part 特別注文部品
 ◆01 Standard parts 標準部品

4. FEED COMPONENTS

送り関係

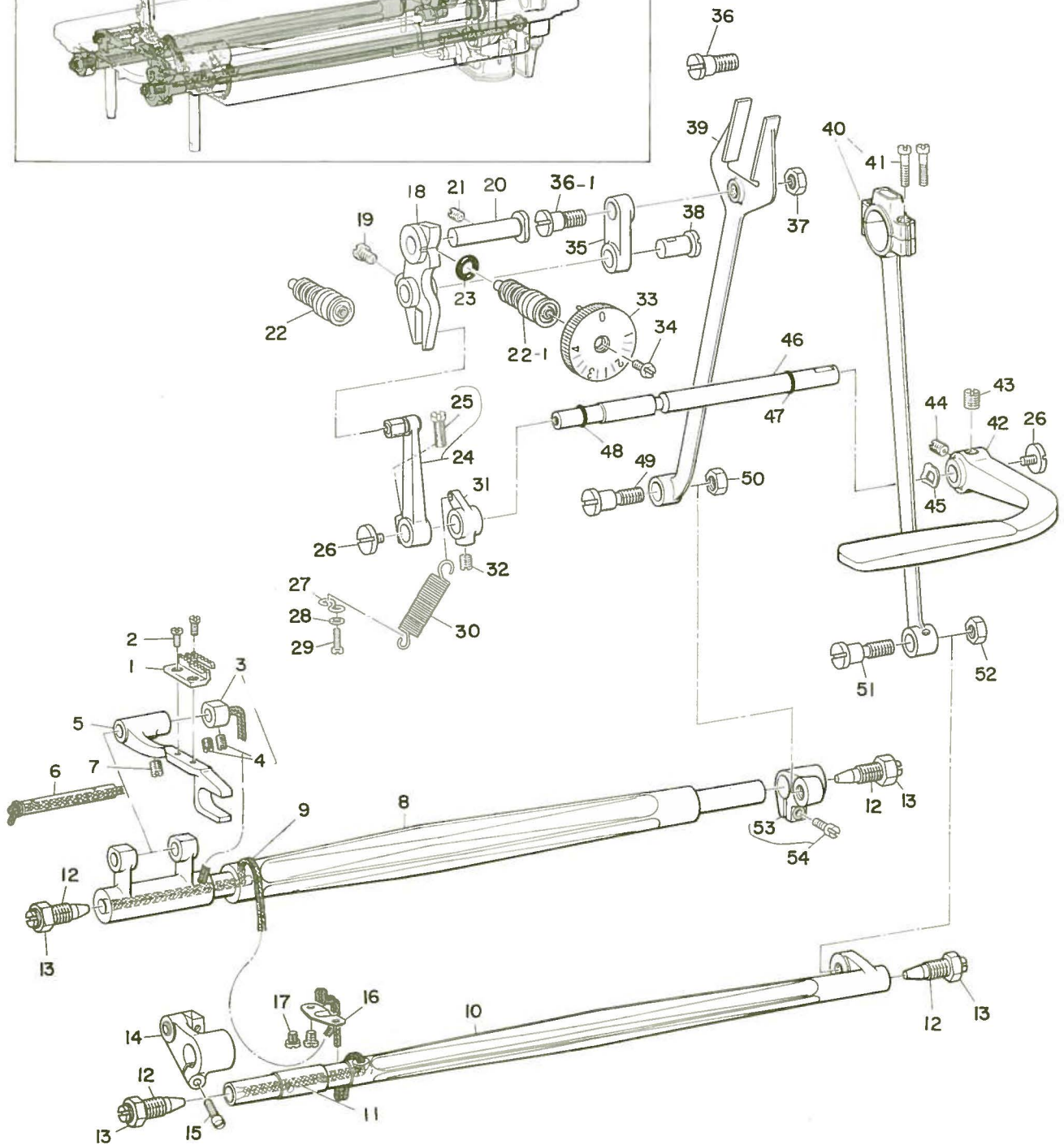
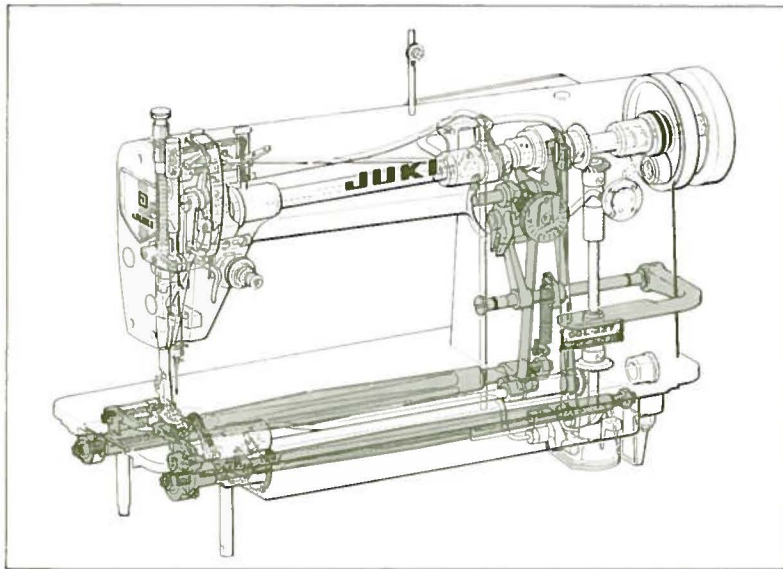

4. FEED COMPONENTS

送り関係

Ref. No.	Note	Part No.	Description	E.C.	品名	Amt. Req.
	注記	品番		変更年月		数量
1	◆01	B1613-012-A00	Feed dog (A)		送り歯(A)	1
2		SS-4080620-TP	... Screw		送り止ネジ	2
3		CS-0640860-SH	Feed bar shaft thrust collar		送り台軸スラスト受け	1
4		SS-8110510-SP	... Screw		送り台軸スラスト受け止ネジ	(2)
5		B1602-012-000	Feed bar		送り台	1
6		B1604-012-000	Feed bar shaft		送り台軸	1
7		SS-8620610-TP	... Screw		送り台軸止ネジ	1
8		B1601-226-000	Feed rock shaft		水平送り軸	1
9		CQ-2020000-00	... Oil wick		水平送り軸油心	0.8
10		B1703-226-000	Feed driving shaft		上下送り軸	1
11		CQ-2020000-00	... Oil wick		上下送り軸油心	0.6
12		B1113-012-000	Center screw asm.		ネジセンター	4
13		NS-6740510-SP	... Nut		ネジセンターナット	(4)
14		B1706-012-0B0	Feed driving shaft crank asm.		上下送り腕(組)	1
15		SS-7111410-SP	... Clamp screw		上下送り腕締ネジ	(1)
16		B1635-552-000	Oil wick holder		送り軸油心押エ	1
17		SS-7110540-SP	... Screw		送り軸油心押エ止ネジ	2
18		B1620-226-000	Feed regulator		送り調節台	1
19		SS-6661110-SP	... Connecting link screw		二又リンク軸止ネジ	1
20		B1622-555-000	... Hinge pin		送り調節台止軸	1
21		SS-8151230-SP	... Screw		送り調節台止軸止ネジ	1
22		B1634-555-000-A	Feed regulating screw	D.1/70	送り調節ネジ	—
22-1		B1634-555-000-B	Feed regulating screw	A.1/70	送り調節ネジ	1
23		RO-0742401-00	... Rubber ring		送り調節ネジOリング	1
24		B1627-226-0B0	Reverse feed control lever crank asm.		送り調節腕(組)	1
25		SS-6121210-SP	... Clamp screw		送り調節腕締ネジ	(1)
26		SS-7620750-SP	... End screw		送り軸押シネジ	2
27		B1648-122-000	Tension spring suspension hook (B)		引張りバネ掛ケ(B)	1
28		WP-0371016-SD	... Washer		引張りバネ掛ケ(B)座金	1
29		SS-4091010-SP	... Screw (B)		引張りバネ掛ケ(B)止ネジ	1
30		B1646-122-000	Tension spring		引張りバネ	1
31		B1647-226-000	... Suspension bracket (A)		引張りバネ掛ケ(A)	1
32		SS-8150710-SP	... Screw (A)		引張りバネ掛ケ(A)止ネジ	1
33	◆01	B1623-555-0A0-A	Stitch dial asm.		目盛板(組)	1
34		SS-6121050-SP	... Screw		目盛板止ネジ	1
35		B1619-226-000	Feed regulator connecting link		二又リンク	1
36	☆	SD-0950802-SP	... Hinge screw	D.5/76	二又リンク段ネジ	1
36-1	☆	SD-0950802-SH	... Hinge screw	A.5/76	二又リンク段ネジ	1
37		NS-6680410-SP	... Nut		二又リンク段ネジナット	1
38		B1618-226-000	... Hinge pin		二又リンク軸	1
39		B1613-125-000	Pitman		二又ロッド	1
40		B1701-125-0A0	Feed driving shaft connecting rod asm.		上下送りロッド(組)	1
41		SS-6121610-SP	... Clamp screw		上下送りロッド蓋締ネジ	(2)
42		B1624-555-000	Reverse feed control lever		送りレバー	1
43		SS-8660970-TP	... Screw (A)		送りレバー止ネジ(A)	1
44		SS-8660810-TP	... Screw (B)		送りレバー止ネジ(B)	1
45		WZ-1052010-KP	... Washer		送りレバー座金	1
46		B1621-226-000	... Shaft		送り調節レバー軸	1
47		RO-0691801-00	... Rubber ring, large		送りレバー軸Oリング(大)	1
48		RO-0611801-00	... Rubber ring, small		送りレバー軸Oリング(小)	1
49		SD-1020961-SP	Hinge		二又ロッド段ネジ	1
50		NS-6680410-SP	... Nut		二又ロッド段ネジナット	1
51		SD-1020961-SP	... Hinge pin		上下送りロッド段ネジ	1
52		NS-6680410-SP	... Nut		上下送りロッド段ネジナット	1
53		B1607-226-0A0	Feed rock shaft crank asm.		水平送り腕(組)	1
54		SS-7111310-SP	... Screw		水平送り腕止ネジ	(1)

Note (注記) ◆01 Standard parts 標準部品

5. OIL LUBRICATION COMPONENTS

給油関係

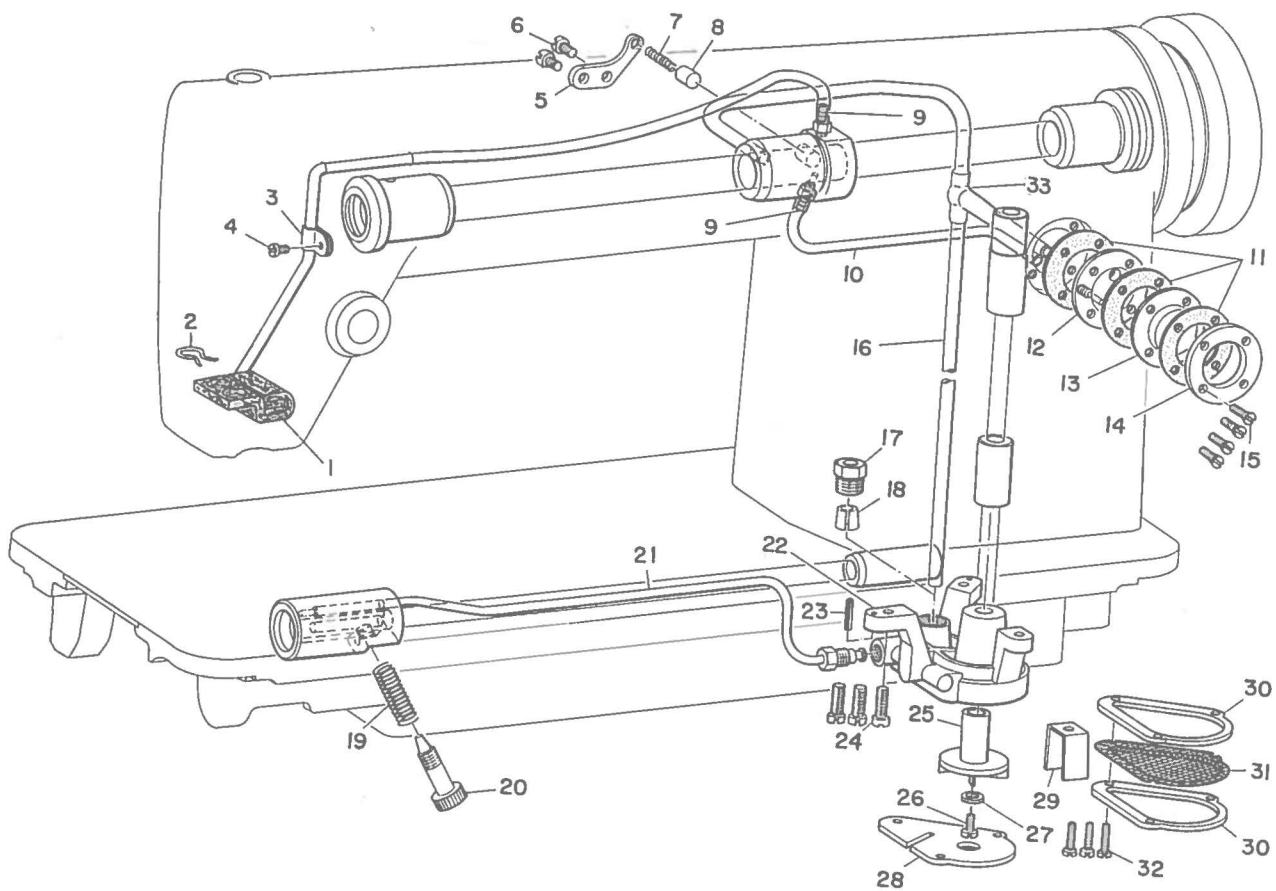

Ref. No.	Note	Part No.	Description	E.C.	Amt. Req.
	注記	品番		変更年月	数量
1		B3526-552-0A0	Oil felt	還流フェルト(組).....	1
2		B3529-226-000	. . . Presser	還流フェルト押エ.....	1
3		B3536-122-000	Oil return tube holder	還流パイプ押エ.....	1
4		SS-7110710-SP	. . . Screw	還流パイプ押エ止ネジ.....	1
5		B3524-552-000	Plunger thrust plate	プランジャー押エ金具.....	1
6		SS-7110910-SP	. . . Screw	プランジャー押エ金具止ネジ.....	2
7		B1214-038-000	. . . Spring	プランジャー押エバネ.....	1
8		B3534-155-000	Lubricating pump plunger	還流ポンププランジャー.....	1
9		SQ-1110402-MZ	Oil tube connecting screw	パイプ連結ネジ.....	2
10		BP-3000000-00	Oil sight window oil tube	油覗キ台パイプ.....	0.2
11		B3516-552-000	Oil sight window gasket	油覗キ窓パッキン.....	3
12		B3531-552-000	Oil sight window base	油覗キ台.....	1
13		B3513-352-000	Oil sight window	油覗キ窓.....	1
14		B3514-552-000	Oil sight window frame	油覗キ窓押エ.....	1
15		SS-2091520-SP	. . . Screw	油覗キ台止ネジ.....	4
16		B3513-227-000	Main shaft oil tube	上軸給油パイプ.....	1
17		B3512-122-000	. . . Clamp screw	上軸給油パイプ固定ネジ.....	1
18		B3511-122-000	. . . Clamp bushing	上軸給油パイプ固定ブッシュ.....	1
19		B2616-372-000	Spring.....	油量調節ネジバネ.....	1
20		B3514-412-000	Oil adjusting screw	下軸前メタル油量調節ネジ.....	1
21		B3521-552-0A0	Hook driving shaft oil tube asm.	釜給油パイプ.....	1
22		B3501-552-000	Lubricating oil pump	給油ポンプ体.....	1
23		PS-0200122-K0	. . . Spring pin	ポンプ体スプリングピン.....	2
24		SS-7121410-SP	. . . Screw	給油ポンプ体止ネジ.....	3
25		B3507-155-000	. . . Impeller	回転軸.....	1
26		SS-6081010-TP Screw	回転軸止ネジ.....	1
27		WP-0550800-SP Washer	回転軸止ネジ座金.....	1
28		B3502-122-000	. . . Cover	給油ポンプ蓋.....	1
29		B3545-122-000	. . . Oil guard	給油ポンプ油除ケ.....	1
30		B3503-122-000	. . . Frame	給油ポンプ枠.....	2
31		B3504-155-000	. . . Filter screen	濾過網.....	1
32		SS-6081210-SP	. . . Screw, for cover	給油ポンプ蓋ネジ.....	3
33		B3527-552-000	Lubrication tube rubber joint	給油パイプゴム接手.....	1

6. OIL RESERVOIR & KNEE LIFTER COMPONENTS

油溜・膝上ゲ関係

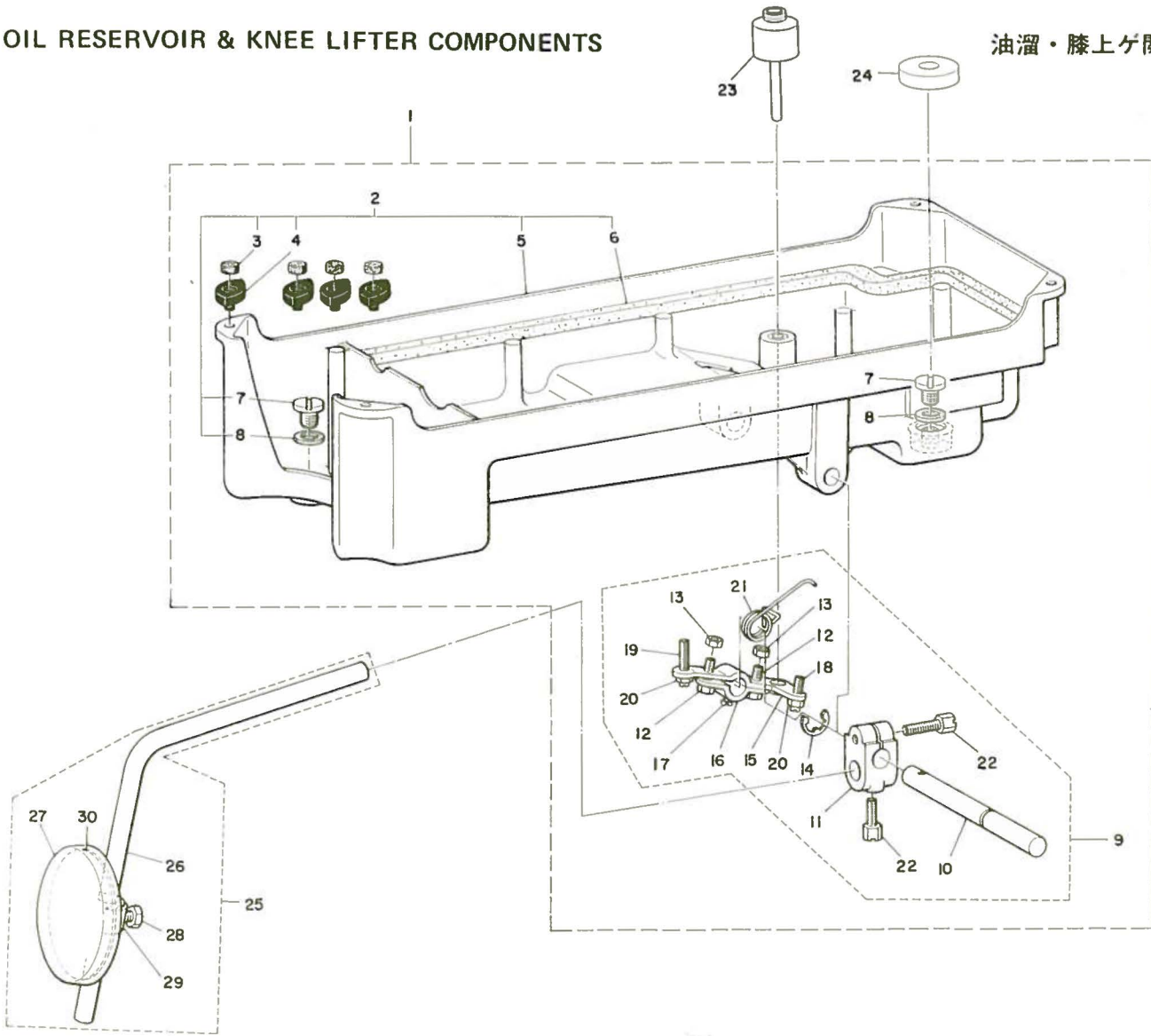

Ref. No.	Note	Part No.	Description	E.C.	Amt. Req.
	注記	品番		変更年月	数量
1		B8217-552-0C0	Oil reservoir asm.	油溜(組)	1
2		B8217-552-0A0	Oil reservoir asm.	油溜(組)	(1)
3		B8227-125-000	Felt pad	頭部クッション	(4)
4		B8226-125-000	Rubber pad	頭部支エゴム	(4)
5		B8217-552-000	Oil reservoir	油溜	(1)
6		B8218-552-000	. . . Gasket	油溜パッキン	(1)
7		SS-6741010-SP	Oil drain cap screw	排油穴蓋ネジ	(2)
8		B8219-125-000	. . . Gasket	排油穴蓋パッキン	(2)
9		B3420-552-0A0	Knee press rod asm.	ヒザ上ゲ横軸(組)	(1)
10		B3420-552-000	Knee press rod	ヒザ当横軸	(1)
11		B3427-122-000	. . . Bearing bracket	ヒザ当立軸取付腕	(1)
12		SS-9151540-SR	Rotating lever clamp screw	ヒザ上ゲ回転腕締ネジ	(2)
13		NS-6150430-SR	. . . Nut	ヒザ上ゲ回転腕締ネジナット	(2)
14		B3426-552-000	. . . Thrust ring	ヒザ当横軸スラスト受け	(1)
15		B3425-552-000	. . . Lifting (B)	ヒザ上ゲ回転腕(B)	(1)
16		B3424-552-000	. . . Lifting (A)	ヒザ上ゲ回転腕(A)	(1)
17		SS-9151220-SR	. . . Screw	ヒザ上ゲ回転腕止ネジ	(1)
18		SS-8152080-SR	. . . Positioning screw (B)	ヒザ上ゲ回転角調節ネジ(B)	(1)
19		SS-8153010-SR	. . . Positioning screw (A)	ヒザ上ゲ回転角調節ネジ(A)	(1)
20		NS-6150430-SR	. . . Nut	ヒザ上ゲ回転角調節ネジナット	(2)
21		B3429-552-000	. . . Spring	ヒザ上ゲ回転腕バネ	(1)
22		SS-9182010-SN	Clamp screw	ヒザ上ゲ立軸取付腕締ネジ	(2)
23		B3421-552-0A0	Knee press lifter rod asm.	ヒザ上ゲ押し棒(組)	1
24		B8228-125-000	Oil reservoir magnet	油溜磁石	1
25		B3419-552-0A0	Knee lifter plate rod asm.	ヒザ当立軸(組)	1
26		B3419-122-000	Knee lifter plate rod	ヒザ当立軸	(1)
27		B3431-552-000	Knee press plate cover	ヒザ当板カバー	(1)
28		SM-9061003-SE	Stopper screw	ヒザ当板ストッパー止ネジ	(1)
29		B3432-552-000	Knee press plate stopper	ヒザ当板ストッパー	(1)
30		B3430-552-000	Knee press plate	ヒザ当板	(1)

EXCLUSIVE PARTS LIST OF DDL-227 SUBCLASS SEWING MACHINES

DDL-227 サブクラス専用部品一覧表

	Description	DDL-227 Standard 標準	DDL-227-A For light weight materials 薄物用	DDL-227-W For P.P. P. P 用	DDL-227-H For heavy weight materials 厚物用	DDL-227-M For 5mm feed 送り量 5mm 用	DDL-227-L For 7mm feed 送り量 7mm 用	品名
1	Throat plate	B1109-012-A00	B1109-012-i00	D1109-155-W00	B1109-555-H0B	*	B1109-555-H0B	針板
2	Needle thread guide pin asm.	B1113-155-0A0	D1113-126-WA0	D1113-126-WA0	B1114-012-000	*	B1114-012-000	糸案内棒 (組)
3	Frame thread guide (A)	B1126-552-000	*	*	B1126-553-000	*	B1126-553-000	アーム糸案内 (A)
4	Counterweight asm.	B1206-552-0A0	*	*	B1206-553-0A0	*	B1206-553-0A0	釣合錘 (組)
5	Needle bar crank	B1209-552-000	B1209-552-A00	B1209-552-A00	B1209-553-000	*	B1209-553-000	針棒クランク
6	Needle bar	B1401-552-A00	B1401-552-D00-A	B1401-552-D00-A	B1401-552-i00	*	B1401-552-i00	針棒
7	Needle bar bushing, lower	B1403-155-000	*	*	B1403-553-000	*	B1403-553-000	針棒下メタル
8	Needle bar thread guide	B1418-541-000	B1418-552-B00	B1418-552-B00	—————	*	B1418-227-L00	針棒糸掛ケ
9	Needle bar thread guide	B1419-155-000	B1419-553-000	B1419-553-000	B1419-553-000	*	B1419-553-000	針棒糸案内
10	Presser spring	B1505-227-000-A	*	*	B1505-552-000-A	*	B1505-552-000-A	押エ調節バネ
11	Hand lifter cam asm.	B1518-552-0A0	B1518-552-AA0	B1518-552-AA0	*	*	*	押エ上ゲカム (組)
12	Hinged presser foot asm.	B1524-012-0A0	*	D1524-126-WA0	B1511-543-BA0	*	B1524-041-EA0	自由押エ (組)
		B1524-012-0B0		D1524-126-WB0	B1511-543-BB0		B1524-041-EB0	
13	Feed dog	B1613-012-A00	B1613-012-i00	D1613-155-W00	B1613-555-H00	*	B1609-201-000-A	送り
14	Stitch dial asm.	B1623-555-0A0-A	*	*	B1623-227-HA0-A	B1623-227-HA0-A	B1623-227-LA0	目盛板 (組)
15	Lubricating hook asm.	B1830-127-0A0	*	*	B1830-555-HA0	*	B1830-555-HA0	給油釜 (組)
16	Bobbin case holder	B1835-012-000	*	*	B1835-555-H00	*	B1835-555-H00	中釜押エ
17	Thread tension post socket	B3111-552-B00	B3111-126-000	B3111-126-000	*	*	*	糸調子棒台
18	Thread tension spring	B3129-012-A00	B3121-352-000	B3121-352-000	B3114-232-000	*	B3114-232-000	糸調子バネ
19	Take-up spring	B3128-012-000	B3128-027-000	B3128-027-000	*	*	*	糸取りバネ
20	Bobbin	B9117-012-000	B9117-552-A00	B9117-552-A00	*	*	*	ボビン
21	Needle	MDB-100B1400	MDA-100B0900	MDA-100B1100	MDB-100B2200	*	MDB-100B2200	針
22	Arm oil shield screw	SS-6080410-SP	*	*	SS-6080320-SP	*	SS-6080320-SP	面部油防板止ネジ
23	Lower shaft front screw asm.	B1808-552-0A0	*	*	B1808-227-HA0	*	B1808-227-HA0	下軸前止ネジ (組)
24	Feed drive eccentric cam	B1210-226-000	*	*	B1210-227-H00	*	B1210-227-H00	送り偏心カム
25	Bobbin case	B1837-012-0A0	*	*	*	D1837-555-BAA	*	ボビンケース
26	Feed rock shaft crank asm.	B1607-226-0A0	*	*	*	*	B1607-201-0A0	水平送り腕 (組)
27	Pitman	B1613-125-000	*	*	*	*	B1613-201-000	二又ロッド
28	. . . Pin	—————	—————	—————	—————	—————	B1611-155-000-A	二又ロッド止メ軸
29	. . . Hinge	SD-1020961-SP	*	*	*	*	—————	二又ロッド段ネジ
30	. . . Screw	—————	—————	—————	—————	—————	SS-7110910-SP	二又ロッド止メ軸止ネジ
31	. . . Nut	NS-6680410-SP	*	*	*	*	—————	二又ロッド段ネジナット
32	Feed regulator	B1620-226-000	*	*	*	*	B1620-227-L00	送り調節台

NOTE (注記) Parts marked with * are same as standard parts

* 標準部品と共通に使用する

————— ... Parts to be removed

————— 取り除く部品

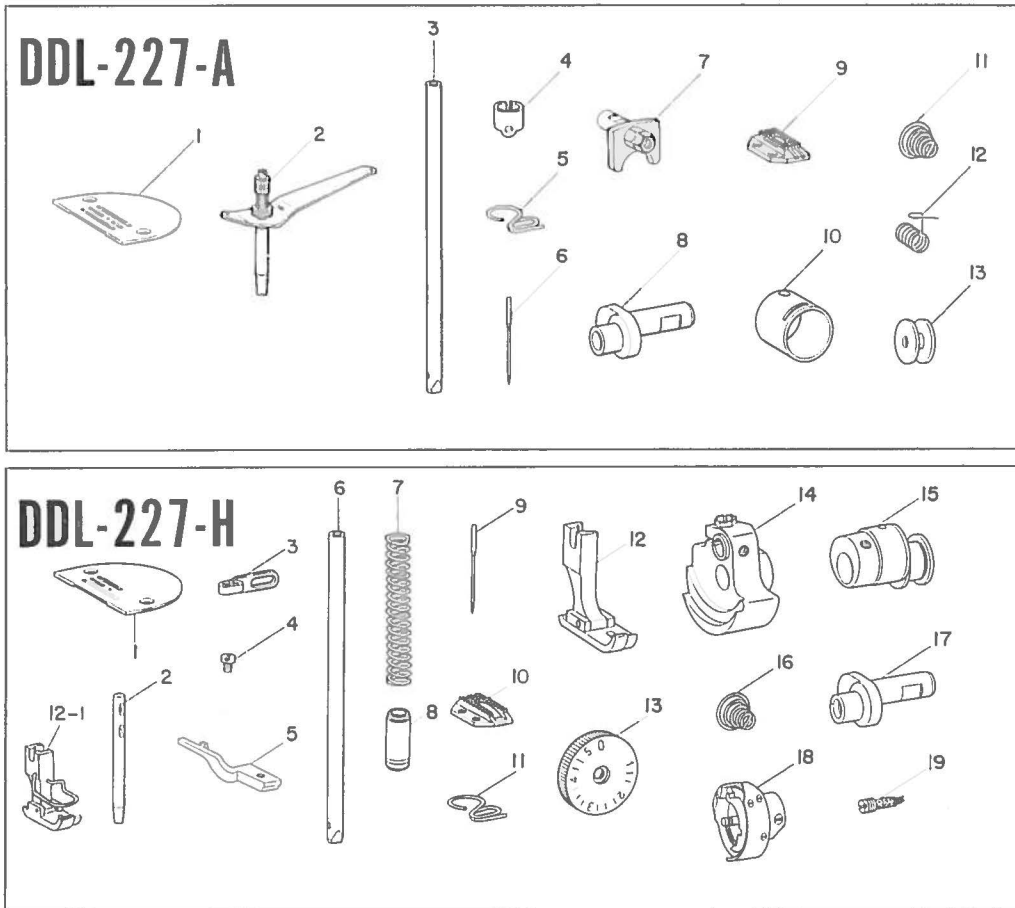

Ref. No.	Note	Part No.	Description	E.C. 変更年月	品名	Amt. Req. 数量
1) DDL-227-A (薄物用) (For light weight materials)						
1		B1109-012-i00	Throat plate (i)		針板(i)	1
2		D1113-126-WA0	Needle thread guide pin asm.		糸案内棒(組)	1
3		B1401-552-D00-A	Needle bar (D)		針棒(D)	1
4		B1418-552-B00	Needle bar thread guide		針棒糸掛ケ	1
5		B1419-553-000	Needle thread guide		針棒糸案内	1
6		MDA-100B0900	Needle DAX1 (88x1, 1128, Ser x 548) #9		針(DA×1 #9)	1
7		B1518-552-AA0	Hand lifter cam asm.		押エ上ゲカム(組)	1
8		B1209-552-A00	Needle bar crank		針棒クランク	1
9		B1613-012-i00	Feed (i)		送り歯(i)	1
10		B3111-126-000	Tension post socket		糸調子棒台	1
11		B3121-352-000	Tension spring		糸調子バネ	1
12		B3128-027-000	Take-up spring		糸取りバネ	1
13		B9117-552-A00	Bobbin (A)		ボビン(A)	1
2) DDL-227-H (For heavy weight materials) (厚物用)						
1		B1109-555-H0B	Throat plate (H)		針板(H)	1
2		B1114-012-000	Needle thread pin asm.		糸案内棒	1
3		B1126-553-000	Arm thread guide (A)		アーム糸案内(A)	1
4		SS-6080320-SP	Arm oil shield screw		面部油防板止ネジ	1
5		B1835-555-H00	Bobbin case holder positioning finger (H)		中釜押エ(H)	1
6		B1401-552-i00	Needle bar		針棒	1
7		B1505-552-000-A	Presser spring		押エ調節バネ	1
8		B1403-553-000	Needle bar bushing, lower		針棒下メタル	1
9		MDB-100B2200	Needle DBx1 (16x231, 1738) #22		針(DB×1 #22)	1
10		B1613-555-H00	Feed (H)		送り歯(H)	1
11		B1419-553-000	Needle bar thread guide		針棒糸案内	1
12		B1511-543-BA0	Hinged presser foot asm.		自由押エ(組)	1
12-1	001	B1511-543-BB0	Hinged presser foot asm.	A.4/76	自由押エ(組)	1
13		B1623-227-HA0-A	Stitch dial asm.		目盛板(組)	1
14		B1206-553-0A0	Counterweight asm.		釣合錘(組)	1
15		B1210-227-H00	Feed drive eccentric		送り偏心カム	1
16		B3114-232-000	Tension spring		糸調子バネ	1
17		B1209-553-000	Needle bar crank		針棒クランク	1
18		B1830-555-HA0	Sewing hook asm.		釜(組)	1
19		B1808-227-HA0	Hook driving shaft front screw		下軸前止ネジ	1
Note (注記) 001 Special order parts						特別注文部品
*All parts besides above are in common use with standard parts of DDL-227						上記以外ノ部品ハ、DDL-227 標準部品ト共通

DDL-227-M

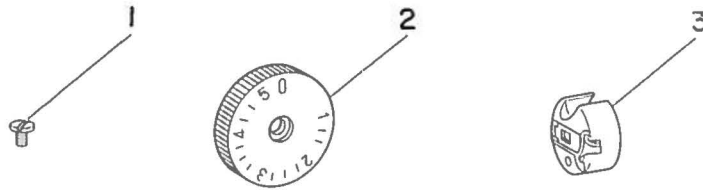

DDL-227-W

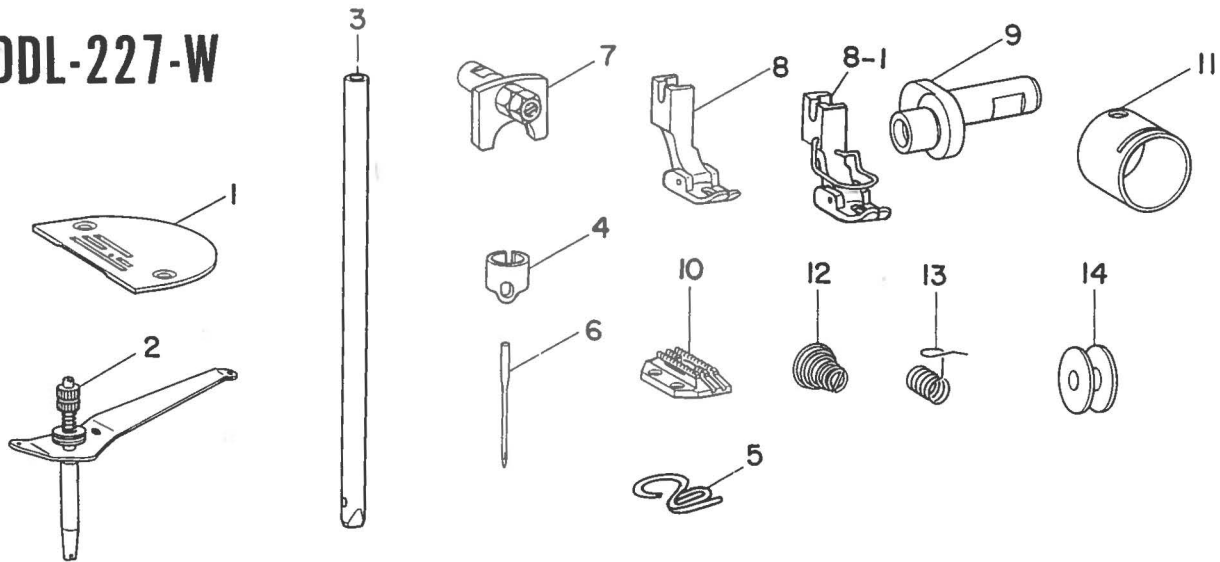

Ref. No.	Note	Part No.	Description	E.C. 変更年月	品名	Amt. Req. 数量
3) DDL-227-M (For 5mm feed) (送り量5mm用)						
1		SS-6080320-SP	Arm oil shield screw	D.6/76	面部油防板止ネジ	1
2		B1623-227-HA0-A	Stitch dial asm.		目盛板(組)	1
3		D1837-555-BAA	Bobbin case (with spring)		ボビンケース(バネ入り)	1
4) DDL-227-W (For P.P.) (P.P用)						
1		D1109-155-W00	Throat plate		針板	1
2		D1113-126-WA0	Needle thread guide pin asm.		糸案内棒(組)	1
3		B1401-552-D00-A	Needle bar		針棒	1
4		B1418-552-B00	Needle bar thread guide		針棒糸掛ケ	1
5		B1419-553-000	Needle thread guide		針棒糸案内	1
6		MDA-100B1100	Needle DAX1 (88x1, 1128, Ser x 548) #11		針(DA×1 #11)	1
7		B1518-552-AA0	Hand lifter cam.		押エ上ゲカム(組)	1
8		D1524-126-WA0	Teflon presser foot asm.		テフロン押エ(組)	1
8-1	◇01	D1524-126-WB0	Teflon presser foot asm.	A.4/76	テフロン押エ(組)	1
9		B1209-552-A00	Needle bar crank		針棒クランク	1
10		D1613-155-W00	Feed		送り歯	1
11		B3111-126-000	Tension post socket		糸調子棒台	1
12		B3121-352-000	Tension spring		糸調子バネ	1
13		B3128-027-000	Take-up spring		糸取りバネ	1
14		B9117-552-A00	Bobbin		ボビン	1
Note (注記) ◇01 Special order parts				特別注文部品		

*All parts besides above are in common use with standard parts of DDL-227 上記以外ノ部品ハ、DDL-227 (標準)部品ト共通

7. SUBCLASS MACHINES

サブクラスマシン

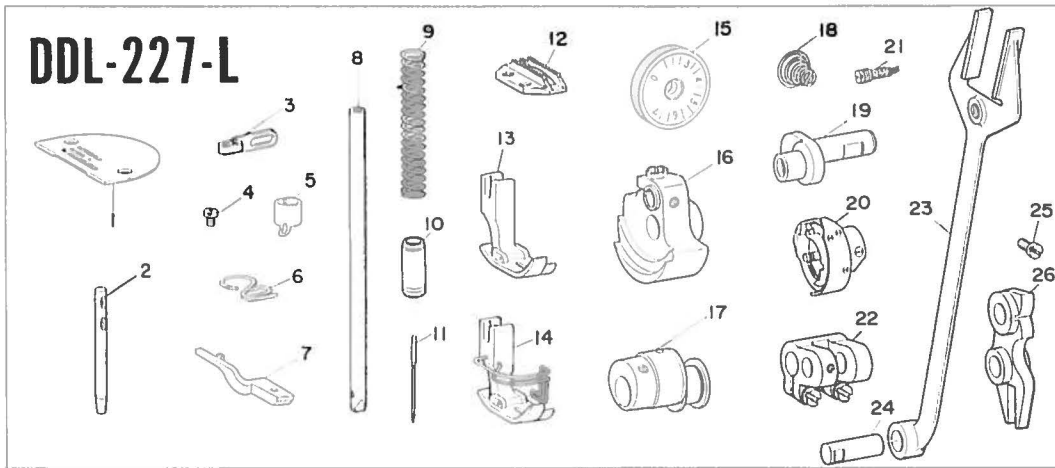

5) DDL-227-L (For 7mm feed) (送り量 7mm用)

1	☆	B1109-555-HOB	Throat plate (H)	A.4/76	針板 (H)	1
2	☆	B1114-012-000	Needle thread guide pin asm.	A.4/76	糸案内棒 (組)	1
3	☆	B1126-553-000	Frame thread guide (A)	A.4/76	アーム糸案内 (A)	1
4	☆	SS-6080320-SP	Arm oil shield screw	A.4/76	面部油防板止ネジ	1
5	☆	B1418-227-L00	Needle bar thread guide	A.4/76	針棒糸掛け	1
6	☆	B1419-553-000	Needle bar thread guide	A.4/76	針棒糸案内	1
7	☆	B1835-555-H00	Bobbin case holder	A.4/76	中签押エ	1
8	☆	B1401-552-i00	Needle bar (i)	A.4/76	針棒 (i)	1
9	☆	B1505-552-000-A	Presser spring	A.4/76	押エ調節バネ	1
10	☆	B1403-553-000	Needle bar bushing, lower	A.4/76	針棒下メタル	1
11	☆	MDB-100B2200	Needle (DB x 1 #22)	A.4/76	針 (DB x 1 #22)	1
12	☆	B1609-201-000-A	Feed dog	A.4/76	送り歯	1
13	☆	B1524-041-EA0	Hinged presser foot asm.	A.4/76	自由押エ (組)	1
14	☆◇01	B1524-041-EB0	Hinged presser foot asm.	A.4/76	自由押エ (組)	1
15	☆	B1623-227-LA0	Stitch dial asm.	A.4/76	目盛板 (組)	1
16	☆	B1206-553-0A0	Counterweight asm.	A.4/76	釣合錘 (組)	1
17	☆	B1210-227-H00	Feed drive eccentric cam	A.4/76	送り偏心カム (H)	1
18	☆	B3114-232-000	Thread tension spring	A.4/76	糸調子バネ	1
19	☆	B1209-553-000	Needle bar crank	A.4/76	針棒クランク	1
20	☆	B1830-155-HA0	Lubricating hook asm.	A.4/76	給油釜 (組)	1
21	☆	B1808-227-HA0	Lower shaft front screw asm.	A.4/76	下軸前止ネジ (組)	1
22	☆	B1607-201-0A0	Feed rock shaft crank asm.	A.4/76	水平送り腕 (組)	1
23	☆	B1613-201-000	Pit man	A.4/76	二又ロッド	1
24	☆	B1611-155-000-A Pin	A.4/76	二又ロッド止メ軸	1
25	☆	SS-7110910-SP Screw	A.4/76	二又ロッド止メ軸止ネジ	1
26	☆	B1620-227-L00	Feed regulator	A.4/76	送り調節台	1

Note (注記) ◇01 Special order parts 特別注文品

* All parts besides above are in common use with standard parts of DDL-227.

上記以外ノ部品ハ、DDL-227 (標準) 部品ト共通

8. SPECIAL ORDER PARTS

特別注文部品

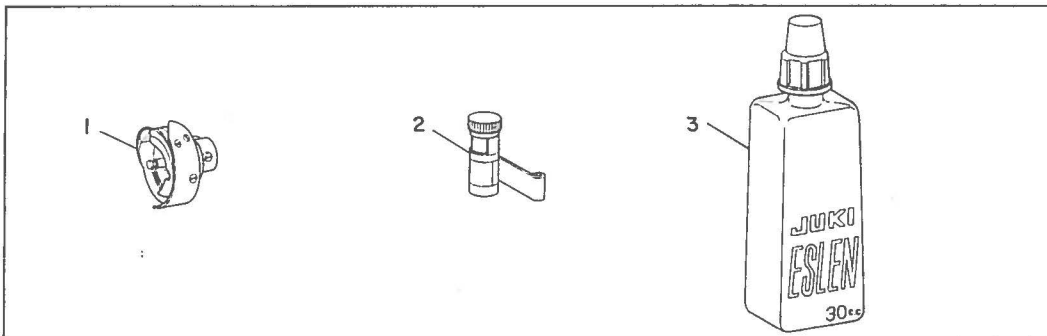

Ref. No.	Note	Part No.	Description	E.C.	品名	Amt. Req.
	注記	品番		変更年月		数量
1		B1830-127-TA0	Hook for tricot asm.		トリコット用釜 (組)	1
2		B1130-541-0A0	Silicon oil lubricating unit case asm.		エスレンケース (組)	1
3		B9135-123-0B0	Silicon oil lubricating unit oiler asm. (30cc)		エスレン油差シ (組) (30cc)	1

9. NUMERICAL INDEX OF PARTS

索引

Part No. 品番	Page 頁	Item 項目	Ref. No.	Part No. 品番	Page 頁	Item 項目	Ref. No.	Part No. 品番	Page 頁	Item 項目	Ref. No.	Part No. 品番	Page 頁	Item 項目	Ref. No.
EXCLUSIVE PARTS		専用部品		B1306-155-0C0	4	2	47	B1621-226-000	8	4	46	B3419-552-0A0	10	6	25
B1104-122-000	2	1	4	B1307-155-0A0	4	2	52	B1622-555-000	8	4	20	B3420-552-0A0	10	6	9
B1105-122-000	2	1	5	B1307-155-0B0	4	2	51	B1623-227-HA0-A	12	7-2	13	B3420-552-000	10	6	10
B1106-122-000	2	1	53	B1308-155-0A0	4	2	53	B1623-227-HA0-A	13	7-3	2	B3421-552-0A0	10	6	23
B1107-122-000	2	1	57	B1401-552-A00	4	2	4	B1623-227-LA0	14	7-5	15	B3424-552-000	10	6	16
B1108-122-000	2	1	55	B1401-552-B00	4	2	5	B1623-555-0A0-A	8	4	33	B3425-552-000	10	6	15
B1109-012-A00	2	1	9	B1401-552-D00-A	12	7-1	3	B1624-555-000	8	4	42	B3426-552-000	10	6	14
B1109-012-i00	12	7-1	1	B1401-552-D00-A	13	7-4	3	B1627-226-0B0	8	4	24	B3427-122-000	10	6	11
B1109-555-H0B	12	7-2	1	B1401-552-i00	12	7-2	6	B1634-555-000-A	8	4	22-1	B3429-552-000	10	6	21
B1109-555-H0B	14	7-5	1	B1401-552-i00	14	7-5	8	B1634-555-000-B	8	4	22	B3430-552-000	10	6	30
B1110-012-0A0	2	1	6	B1402-552-000-A	4	2	2	B1635-552-000	8	4	16	B3431-552-000	10	6	27
B1111-012-000	2	1	7	B1403-155-000	4	2	8	B1646-122-000	8	4	30	B3431-581-000	6	3	25
B1113-155-0A0	2	1	23	B1403-553-000	12	7-2	8	B1647-226-000	8	4	31	B3432-552-000	10	6	29
B1113-012-000	8	4	12	B1403-553-000	14	7-5	10	B1648-122-000	8	4	31	B3501-552-000	9	5	22
B1113-155-000	2	1	24	B1405-012-000	4	2	1	B1701-125-0A0	8	4	40	B3502-122-000	9	5	28
B1114-012-000	12	7-2	2	B1408-552-000	4	2	15	B1703-226-000	8	4	10	B3503-122-000	9	5	30
B1114-012-000	14	7-5	2	B1411-552-0A0	4	2	6	B1706-012-0B0	8	4	14	B3504-155-000	9	5	31
B1117-552-000	2	1	16	B1414-232-000	4	2	14	B1801-412-000	6	3	43	B3507-155-000	9	5	25
B1117-552-000	2	1	17	B1418-227-L00	14	7-5	5	B1802-412-0A0	6	3	46	B3511-122-000	9	5	18
B1118-552-000	2	1	19	B1418-227-T00	4	2	13	B1804-226-000	6	3	40	B3512-122-000	9	5	17
B1119-522-000	2	1	20	B1418-541-000	4	2	10	B1806-038-000	6	3	41	B3513-227-000	9	5	16
B1121-552-0A0	2	1	1	B1418-552-B00	12	7-1	4	B1808-227-HA0	12	7-2	19	B3513-352-000	9	5	13
B1122-552-000	2	1	11	B1418-552-B00	13	7-4	4	B1808-227-HA0	14	7-4	21	B3514-412-000	9	5	20
B1123-552-000-A	2	1	29	B1419-155-000	4	2	9	B1808-552-0A0	6	3	50	B3514-552-000	9	5	14
B1126-552-000	2	1	33	B1419-553-000	12	7-1	5	B1809-552-0A0	6	3	51	B3516-552-000	9	5	11
B1126-553-000	12	7-2	3	B1419-553-000	12	7-2	11	B1810-552-000	6	3	51	B3521-552-0A0	9	5	21
B1126-553-000	14	7-5	3	B1419-553-000	13	7-2	5	B1830-127-TA0	14	8	1	B3524-552-000	9	5	5
B1128-522-000	2	1	31	B1419-553-000	14	7-5	6	B1830-127-0A0	6	3	54	B3526-226-0A0	9	5	1
B1130-541-0A0	14	8	2	B1421-522-000	6	3	14	B1830-555-HA0	12	7-2	18	B3527-552-000	9	5	33
B1147-555-000	2	1	50	B1501-127-000	6	3	5	B1830-555-HA0	14	7-5	20	B3529-226-000	9	5	2
B1148-555-000	2	1	51	B1502-541-000	6	3	10	B1835-012-000	6	3	48	B3531-552-000	9	5	12
B1164-012-000	2	1	15	B1505-227-T00-A	6	3	4	B1835-555-H00	12	7-2	5	B3534-155-000	9	5	8
B1166-552-000-A	2	1	52	B1505-227-000-A	6	3	3	B1835-555-H00	14	7-5	7	B3536-122-000	9	5	3
B1179-552-000	2	1	3	B1505-552-000-A	12	7-2	7	B1837-012-0A0	6	3	56	B3545-122-000	9	5	29
B1186-552-000	2	1	28	B1505-552-000-A	14	7-5	9	B1901-552-0C0	4	2	22	B8217-552-0A0	10	6	2
B1187-552-000	2	1	22	B1507-552-000	6	3	6	B1903-552-000	4	2	17	B8217-552-0C0	10	6	1
B1188-552-0A0	2	1	12	B1509-227-000	6	3	1	B1904-552-0A0	4	2	19	B8217-552-000	10	6	5
B1189-415-000	2	1	18	B1510-227-000	6	3	2	B1905-541-B00	4	2	18	B8218-552-000	10	6	6
B1201-227-000	4	2	24	B1511-543-BA0	12	7-2	12	B2616-372-000	9	5	19	B8219-125-000	10	6	8
B1202-552-000-A	4	2	35	B1511-543-BB0	12	7-2	12-1	B3111-126-000	12	7-1	10	B8226-125-000	10	6	4
B1203-227-000	4	2	38	B1515-552-000	6	3	20	B3111-126-000	13	7-4	11	B8227-125-000	10	6	3
B1204-552-B00	4	2	55	B1516-552-000	6	3	23	B3111-552-B00	2	1	42	B8228-125-000	10	6	24
B1206-552-0A0	4	2	28	B1517-552-000	6	3	24	B3111-552-0A0	2	1	40	B9117-012-000	6	3	57
B1206-553-0A0	12	7-2	14	B1518-552-AA0	12	7-1	7	B3114-232-000	12	7-2	16	B9117-552-A00	12	7-1	13
B1206-553-0A0	14	7-5	16	B1518-552-AA0	13	7-4	7	B3114-232-000	14	7-5	18	B9117-552-A00	13	7-4	14
B1208-552-000-A	4	2	57	B1518-552-0A0	6	3	17	B3114-761-000	2	1	35	B9135-123-0B0	14	8	3
B1209-552-A00	12	7-1	8	B1520-552-000	6	3	15	B3115-552-000	2	1	44	BP-3000000-00	9	5	10
B1209-552-A00	13	7-4	9	B1521-552-000	6	3	8	B3116-125-000	2	1	49	D1109-155-W00	13	7-4	1
B1209-552-000	4	2	16	B1522-552-000	6	3	19	B3118-552-C00	2	1	39	D1113-126-WA0	12	7-1	2
B1209-553-000	12	7-2	17	B1523-226-000	6	3	27	B3120-125-000	2	1	48	D1113-126-WA0	13	7-4	2
B1209-553-000	14	7-5	19	B1524-012-0A0	6	3	12	B3121-352-000	12	7-1	11	D1524-126-WA0	13	7-4	8
B1210-226-000	4	2	45	B1524-012-0B0	6	3	58	B3121-352-000	13	7-4	12	D1524-126-WB0	13	7-4	8-1
B1210-227-H00	12	7-2	15	B1524-041-EA0	14	7-5	13	B3126-012-000	2	1	45	D1613-155-W00	13	7-4	10
B1210-227-H00	14	7-5	17	B1524-041-EB0	14	7-5	14	B3127-127-000	2	1	38	D1837-555-BAA	13	7-3	3
B1211-226-000	4	2	42	B1601-226-000	8	4	8	B3128-012-000	2	1	43				
B1212-552-A00	4	2	31	B1602-012-000	8	4	5	B3128-027-000	12	7-1	12	THRUST COLLAR			
B1212-012-000	4	2	43	B1604-012-000	8	4	6	B3128-027-000	13	7-4	13	スラストカラー			
B1213-552-0A0	4	2	25	B1607-201-0A0	14	7-5	22	B3129-012-A00	2	1	47	CS-0640860-SH	8	4	3
B1213-012-000	4	2	44	B1607-226-0A0	8	4	53	B3132-552-000	2	1	46	CS-0791010-SH	6	3	44
B1214-038-000	9	5	7	B1609-201-000-A	14	7-5	12	B3148-123-000	2	1	25	CS-079106A-SH	6	3	52
B1217-555-000	4	2	58	B1611-155-000-A	14	7-5	24	B3149-123-A00	2	1	26	CS-147121A-SH	4	2	40
B1224-552-000	4	2	26	B1613-012-A00	8	4	1	B3412-552-000	6	3	28				
B1226-552-000	4	2	27	B1613-012-i00	12	7-1	9	B3413-227-000	6	3	34	NEEDLE	針		
B1233-012-000	4	2	60	B1613-125-000	8	4	39	B3414-552-000	6	3	31	MDA-100B0900	12	7-1	6
B1301-552-000	4	2	61	B1613-201-000	14	7-5	23	B3415-552-000	6	3	38	MDA-100B1100	13	7-4	6
B1302-552-000-A	4	2	62	B1613-555-H00	12	7-2	10	B3416-012-000	6	3	35	MDB-100B1400	4	2	11
B1303-552-000-A	4	2	63	B1618-226-000	8	4	38	B3416-552-000	6	3	29	MDB-100B2200	12	7-2	9
B1305-012-0A0	4	2	49	B1619-226-000	8	4	35	B3417-552-000	6	3	33	MDB-100B2200	14	7-5	11
B1306-155-0A0	4	2	50	B1620-226-000	8	4	18	B3418-552-000	6	3	36				
B1306-155-0B0	4	2	48	B1620-227-L00	14	7-5	26	B3419-122-000	10	6	26				

Part No. 品番	Page 頁	Item 項目	Ref. No.	Part No. 品番	Page 頁	Item 項目	Ref. No.	Part No. 品番	Page 頁	Item 項目	Ref. No.	Part No. 品番	Page 頁	Item 項目	Ref. No.
OIL WICK		油心		RO-0742401-00	8	4	23	SS-6092420-SP	2	1	56	SS-8150310-SP	6	3	11
CQ-2000000-00	4	2	23	RO-2943101-00	4	2	56	SS-6110560-TP	6	3	55	SS-8150710-SP	2	1	37
CQ-2020000-00	2	1	13					SS-6111010-SP	6	3	49	SS-8150710-SP	8	4	32
CQ-2020000-00	4	2	20	HINGE SCREW				SS-6121050-SP	8	4	34	SS-8150710-TP	4	2	46
CQ-2020000-00	4	2	64	SD-0380552-SL	2	1	27	SS-6121210-SP	8	4	25	SS-8151150-SP	4	2	21
CQ-2020000-00	8	4	9	SD-0630275-SP	6	3	21	SS-6121610-SP	8	4	41	SS-8151150-SP	4	2	36
CQ-2020000-00	8	4	11	SD-0630301-SP	6	3	22	SS-6661110-SP	8	4	19	SS-8151150-SP	4	2	37
				SD-0720331-SP	6	3	32	SS-6741010-SP	10	6	7	SS-8151150-SP	6	3	47
NUT		ナット		SD-0950802-SH	8	4	36-1	SS-7080510-SP	4	2	12	SS-8151230-SP	8	4	21
NS-6060350-SP	2	1	36	SD-0950802-SP	8	4	36	SS-7091110-SP	6	3	13	SS-8151550-SP	4	2	59
NS-6150310-SP	2	1	54	SD-1020961-SP	8	4	49	SS-7110510-SP	2	1	30	SS-8151550-SP	6	3	42
NS-6150430-SR	10	6	13	SD-1020961-SP	8	4	51	SS-7110540-SP	8	4	17	SS-8152080-SR	10	6	18
NS-6150430-SR	10	6	20					SS-7110710-SP	9	5	4	SS-8153010-SR	10	6	19
NS-6620310-SP	6	3	39	SCREW				SS-7110910-SP	2	1	21	SS-8620610-TP	8	4	7
NS-6680410-SP	8	4	37	SM-9061003-SE	10	6	28	SS-7110910-SP	9	5	6	SS-8660610-TP	4	2	32
NS-6680410-SP	8	4	50	SQ-1110402-MZ	9	5	9	SS-7110910-SP	14	7-5	25	SS-8660610-TP	4	2	41
NS-6680410-SP	8	4	52	SS-2091520-SP	9	5	15	SS-7111120-SP	2	1	2	SS-8660810-TP	4	2	54
NS-6740510-SP	8	4	13	SS-2110920-TP	2	1	10	SS-7111310-SP	8	4	54	SS-8660810-TP	8	4	44
				SS-4080620-TP	8	4	2	SS-7111410-SP	6	3	7	SS-8660970-TP	8	4	43
SPRING PIN		割ピン		SS-4091010-SP	8	4	29	SS-7111410-SP	8	4	15	SS-8681950-SP	4	2	30
PS-0200122-K0	9	5	23	SS-5090610-SP	2	1	34	SS-7120910-SP	6	3	16	SS-9151220-SR	10	6	17
				SS-6060210-SP	2	1	8	SS-7121410-SP	9	5	24	SS-9151540-SR	10	6	12
SNAP RING		E リング		SS-6080320-SP	12	7-2	4	SS-7151120-SP	4	2	39	SS-9182010-SN	10	6	22
RE-0500000-K0	6	3	30	SS-6080320-SP	13	7-3	1	SS-7620750-SP	8	4	26	SS-9661120-CP	4	2	29
RE-0500000-K0	6	3	37	SS-6080320-SP	14	7-5	4	SS-7681650-TP	4	2	33				
RE-0600000-K0	6	3	26	SS-6080410-SP	2	1	14	SS-8090670-SP	2	1	41	WASHER			座金
				SS-6081010-TP	9	5	26	SS-8110410-TP	6	3	53	WP-0371016-SD	8	4	28
RUBBER RING		O リング		SS-6081210-SP	9	5	32	SS-8110510-SP	2	1	32	WP-0550800-SP	9	5	27
RO-0442401-00	4	2	34	SS-6090650-SP	6	3	9	SS-8110510-SP	8	4	4	WP-0740516-SP	6	3	18
RO-0611801-00	8	4	48	SS-6090670-TP	4	2	7	SS-8110520-TP	6	3	45	WZ-1052010-KP	8	4	45
RO-0691801-00	8	4	47	SS-6091510-SP	2	1	58	SS-8150310-SP	4	2	3				

M E M O

BELT COVER FOR LOCKSTITCH
本縫用ベルトカバー

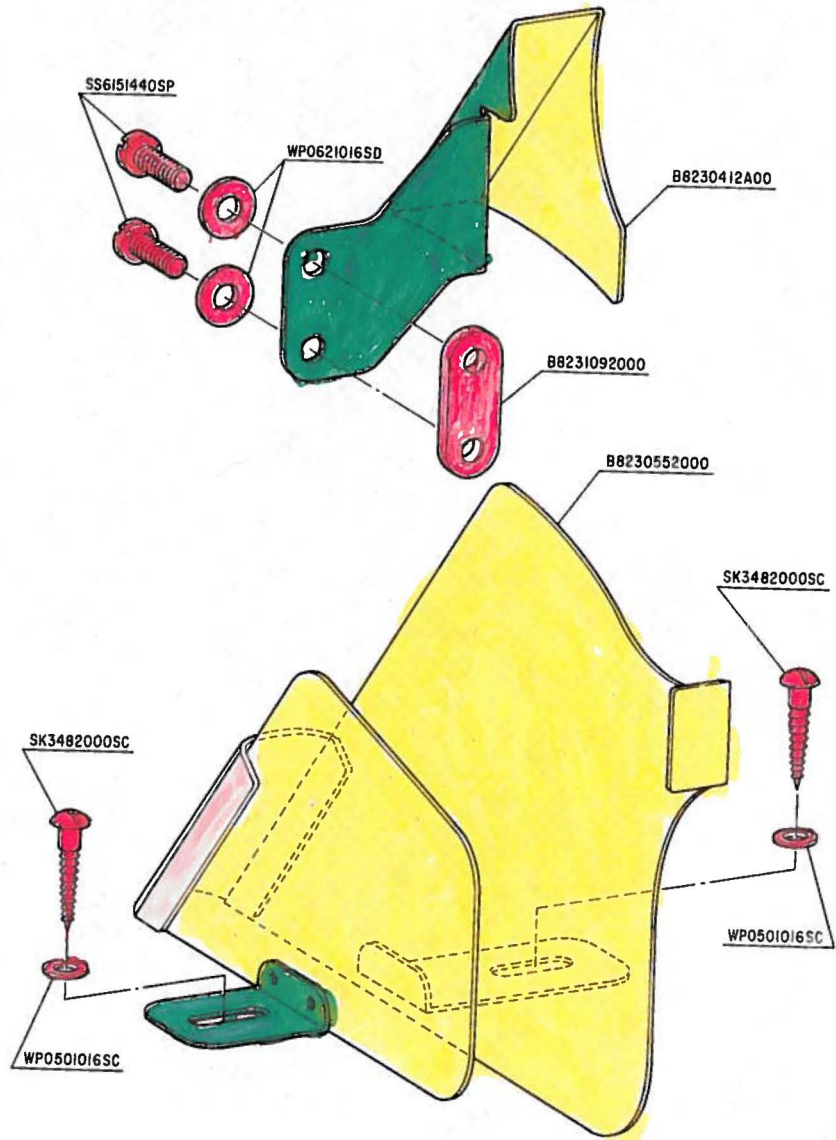

TOKYO JUKI INDUSTRIAL CO.,LTD.

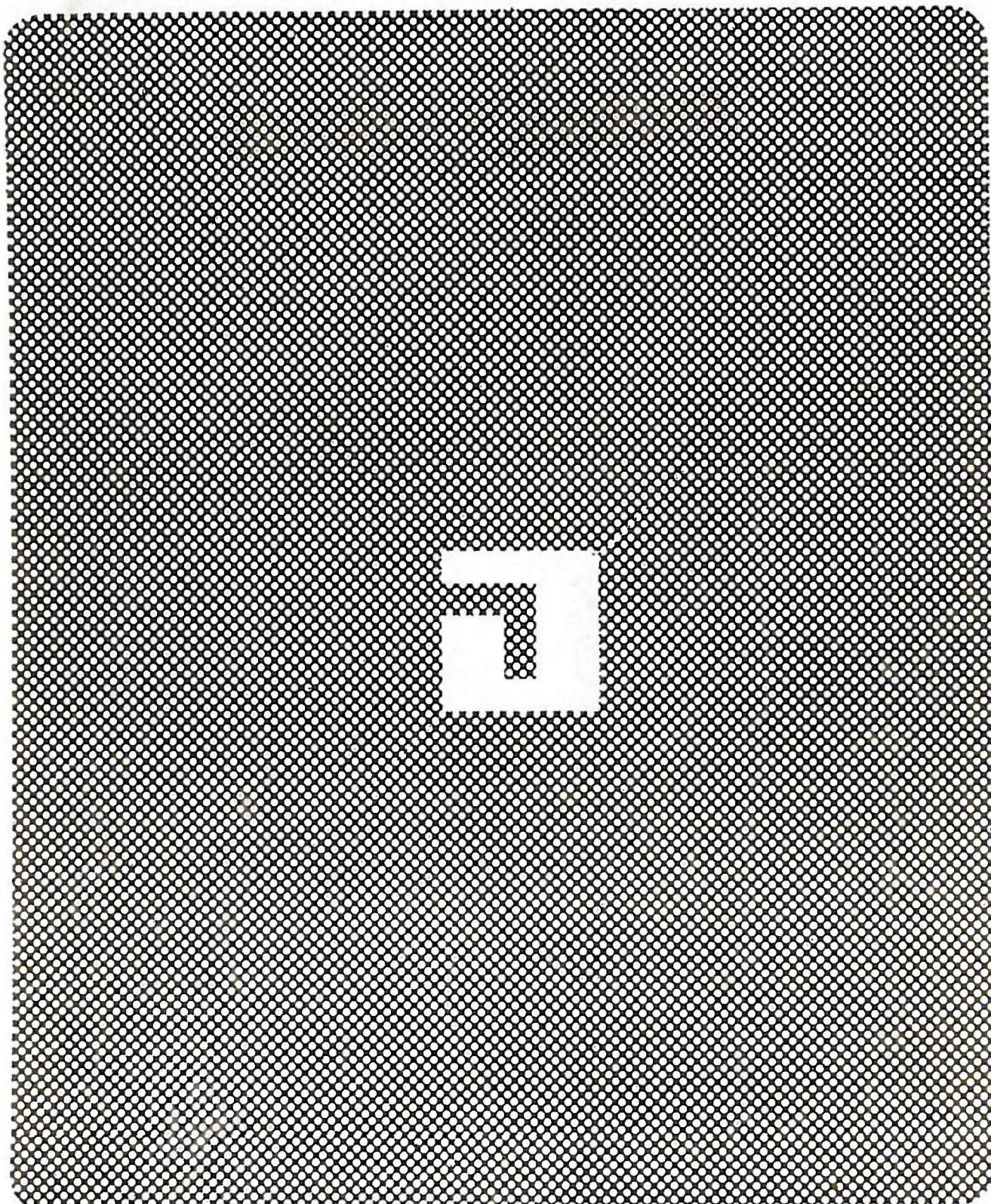

JUKI[®]
TOKYO JUKI INDUSTRIAL CO.,LTD.
Business Office : 23, Kabuki-cho, Shinjuku-ku, Tokyo, Japan
Cable Address : JUKI TOKYO
Telex : 22967 JUKITK
Telephone : Tokyo 203-8241

東京重機工業株式会社
本社工場 東京都調布市国領町8-2-1 ☎(03)480-3111(代)

Printed in Japan(T)